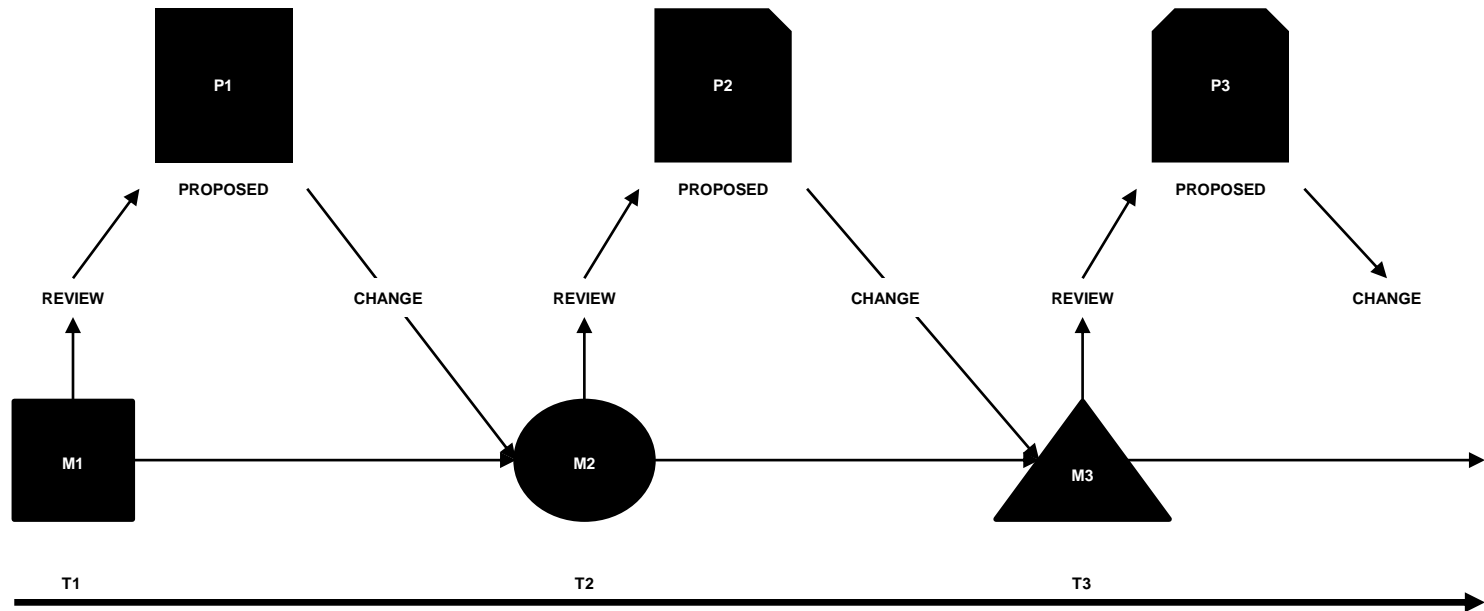

Fig 3.1 The Perpetually Failing Problem Solving Engine



KEY

P = PROCESS

M = MEASUREMENT

T = TIME

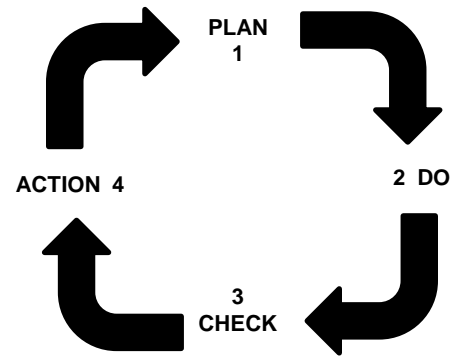

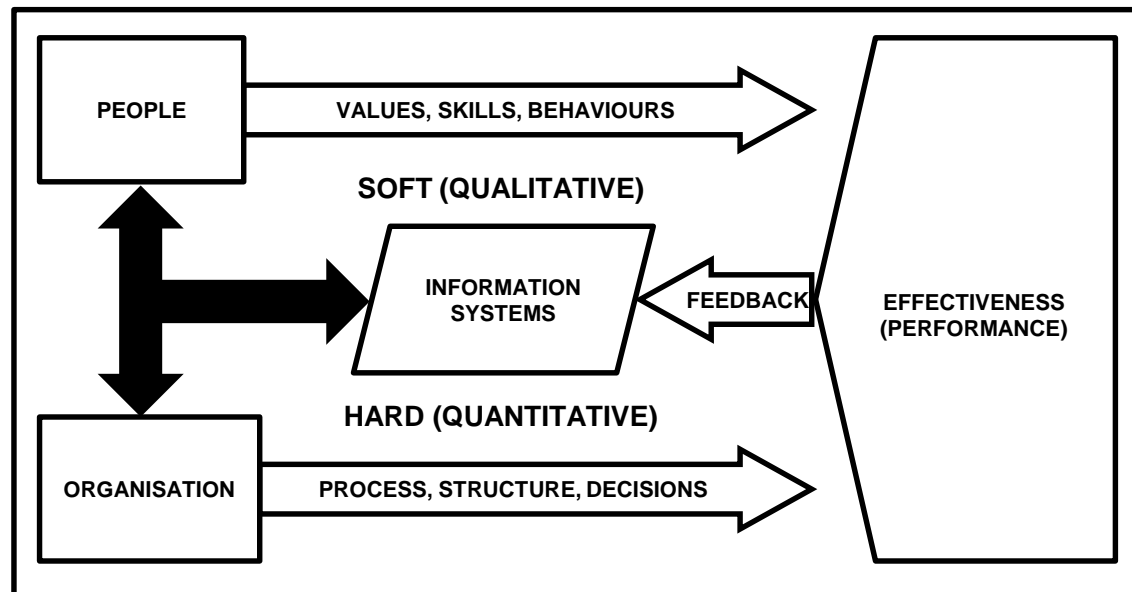
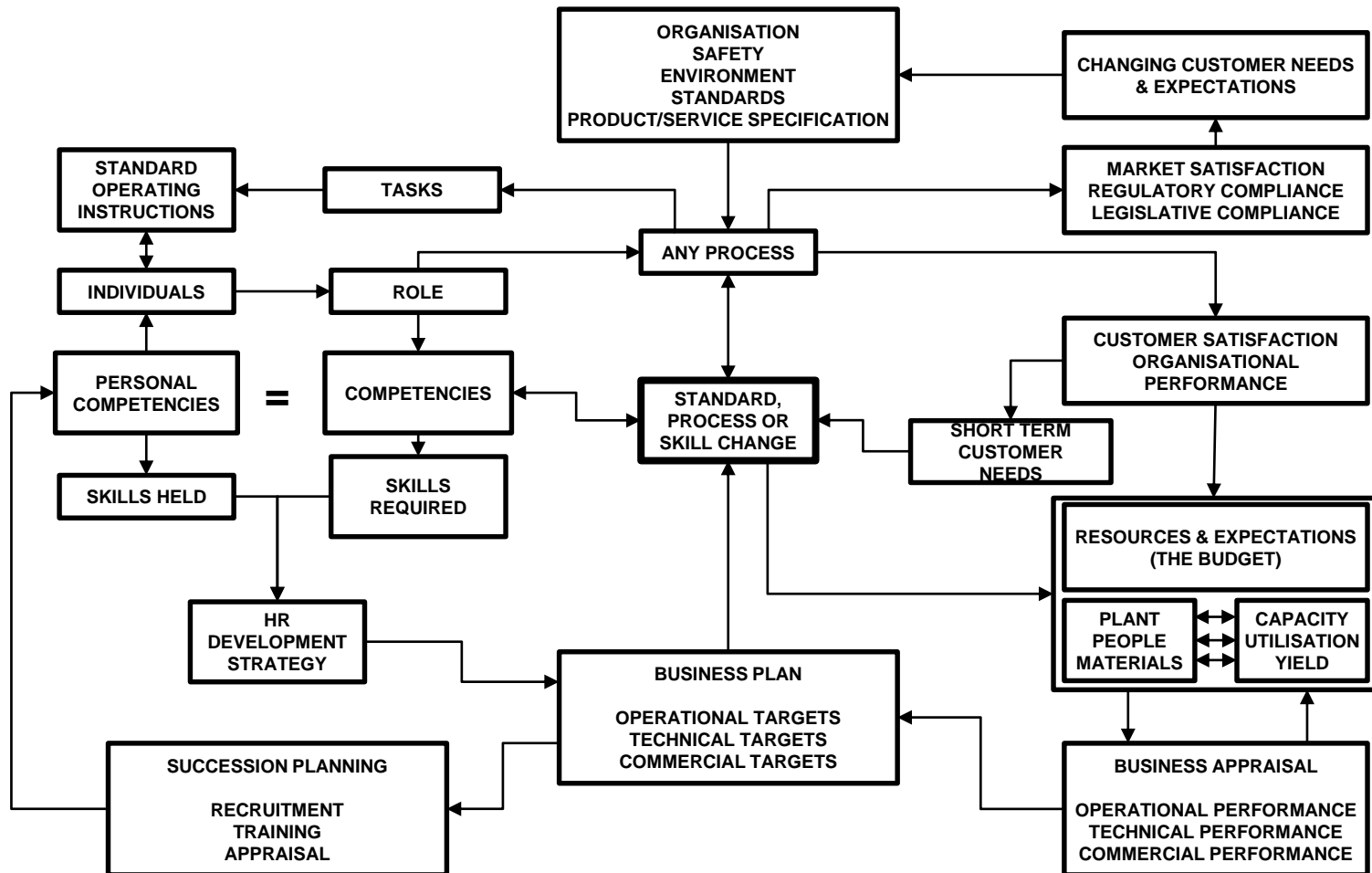

Fig 3.4 The Interdependence of Organisations



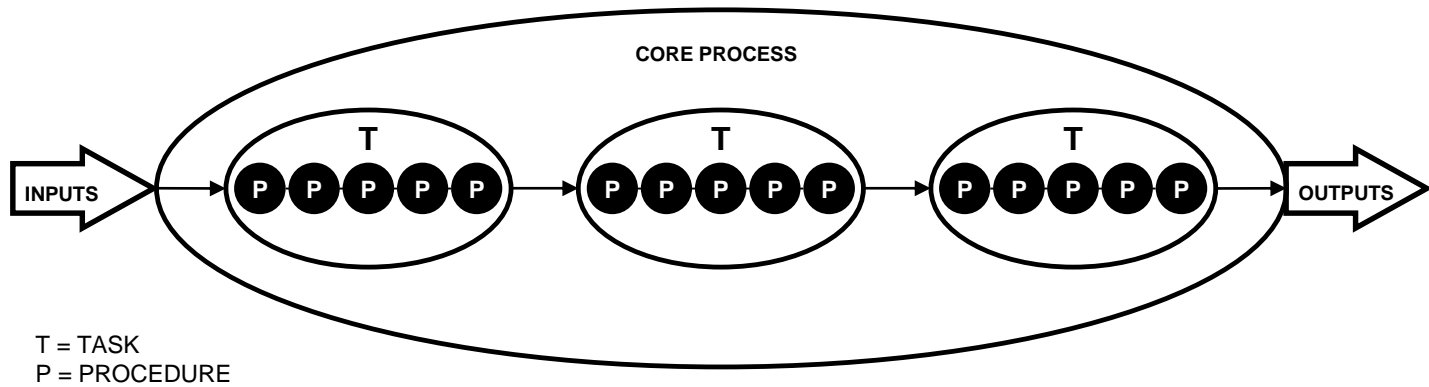
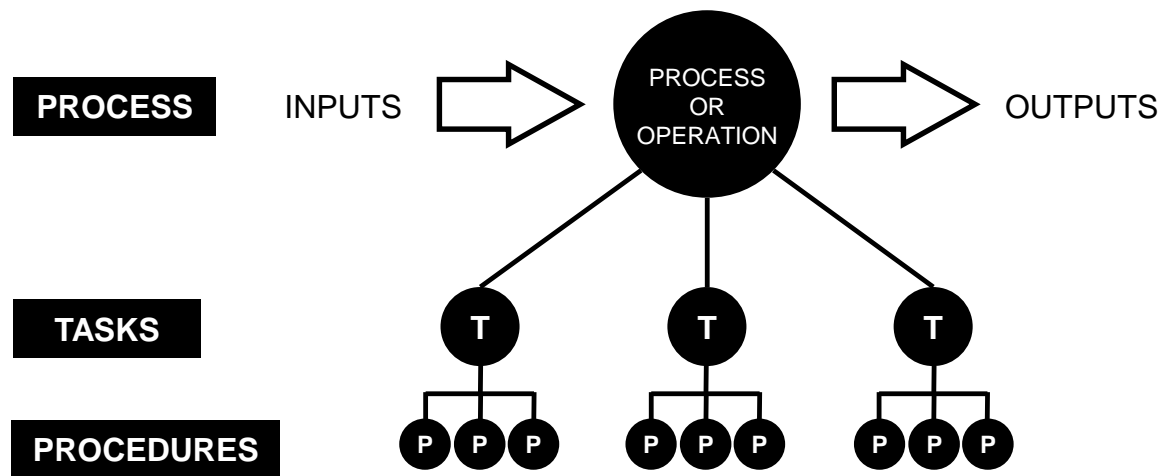
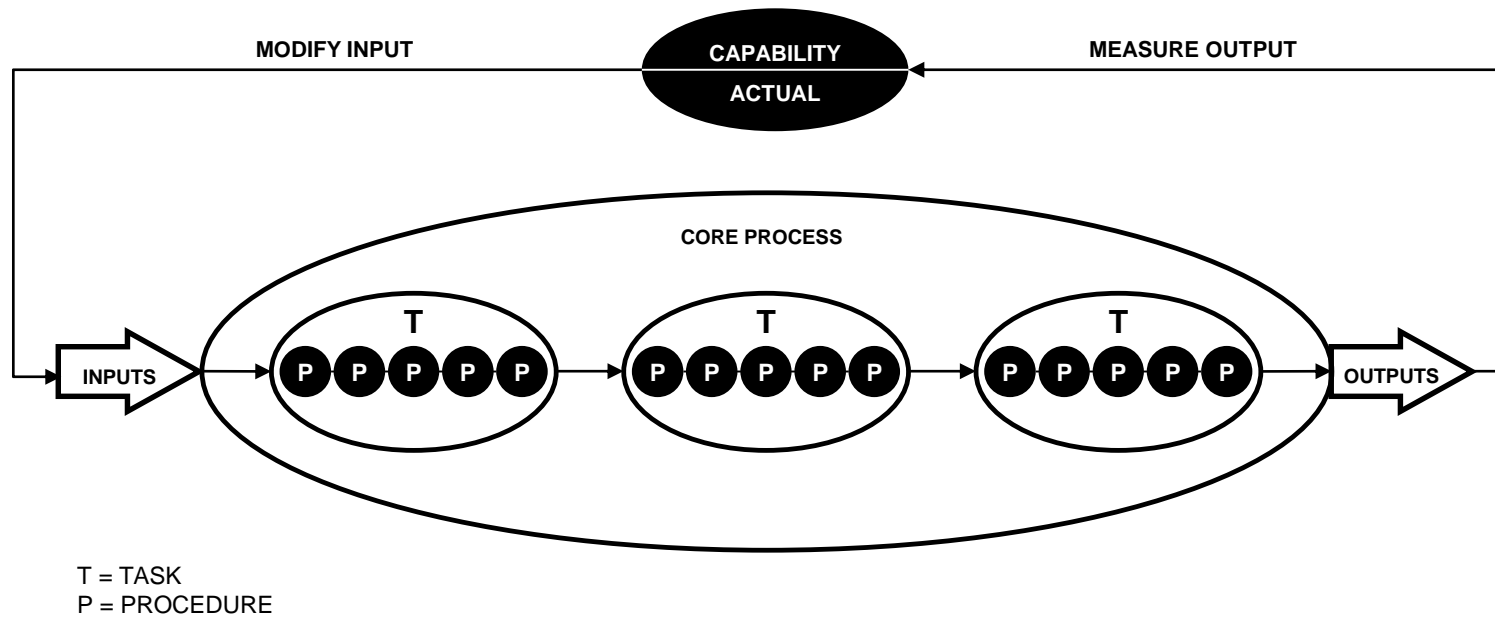

Fig 3.6 Processes, Tasks and Procedures





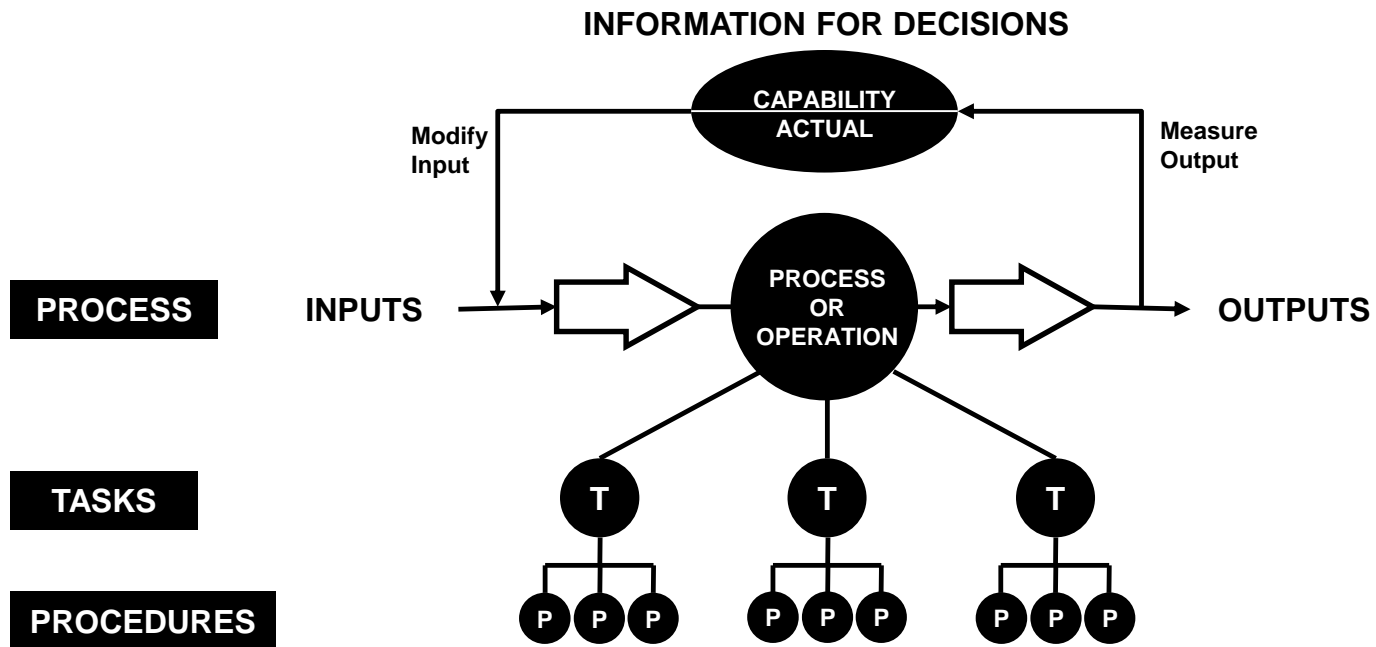
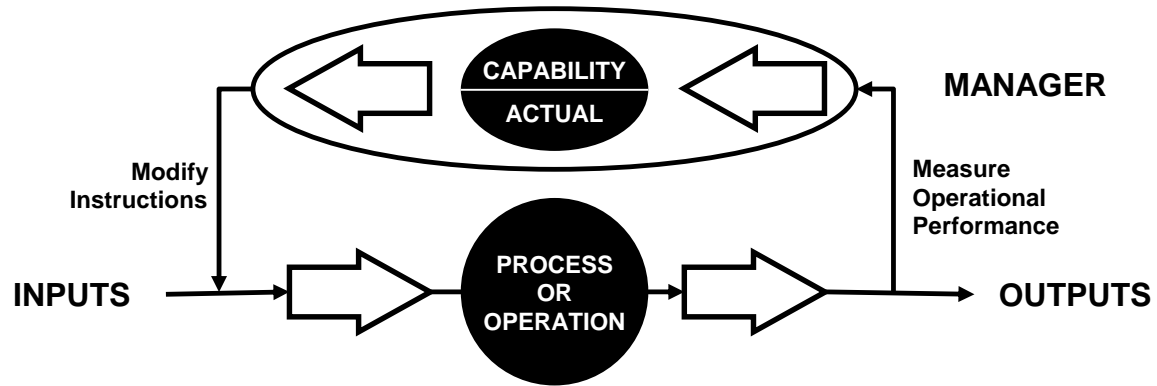

Fig 3.9 The Process of Management



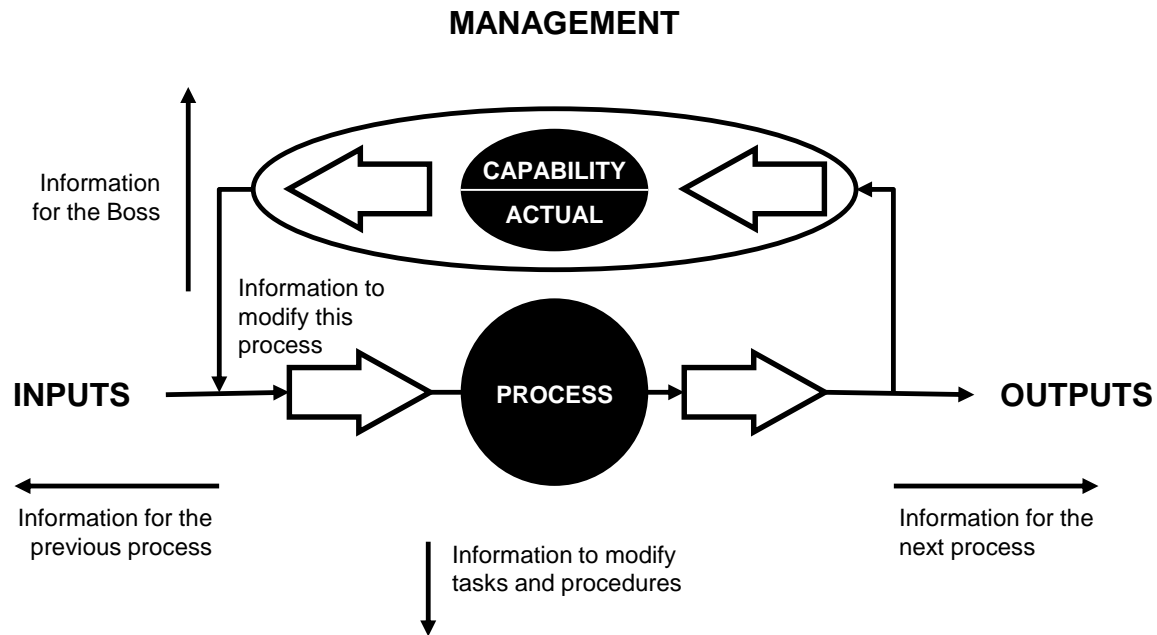
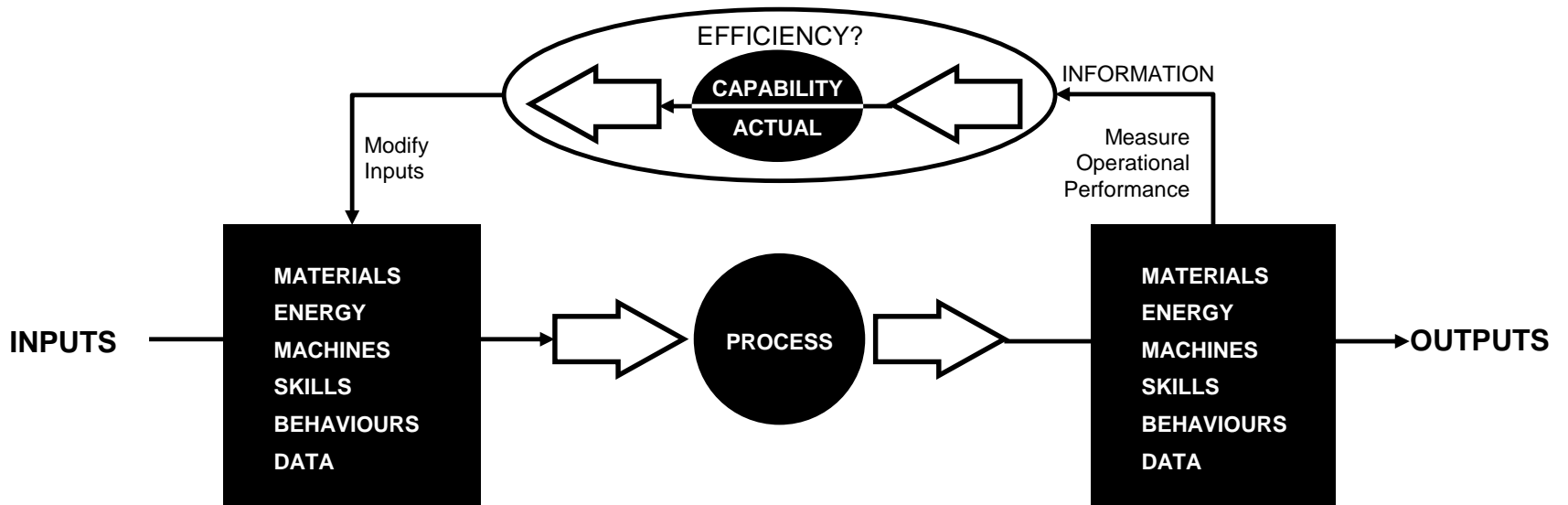

Fig 3.11 The Expanded Homeostat



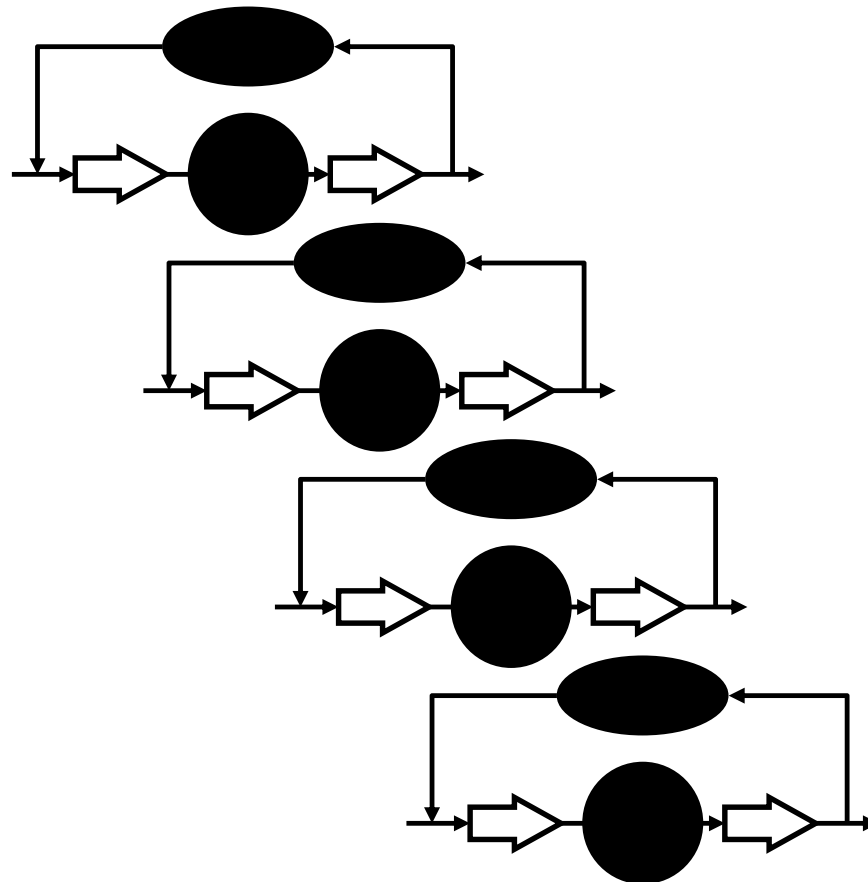

Fig 3.13 The Management of Management

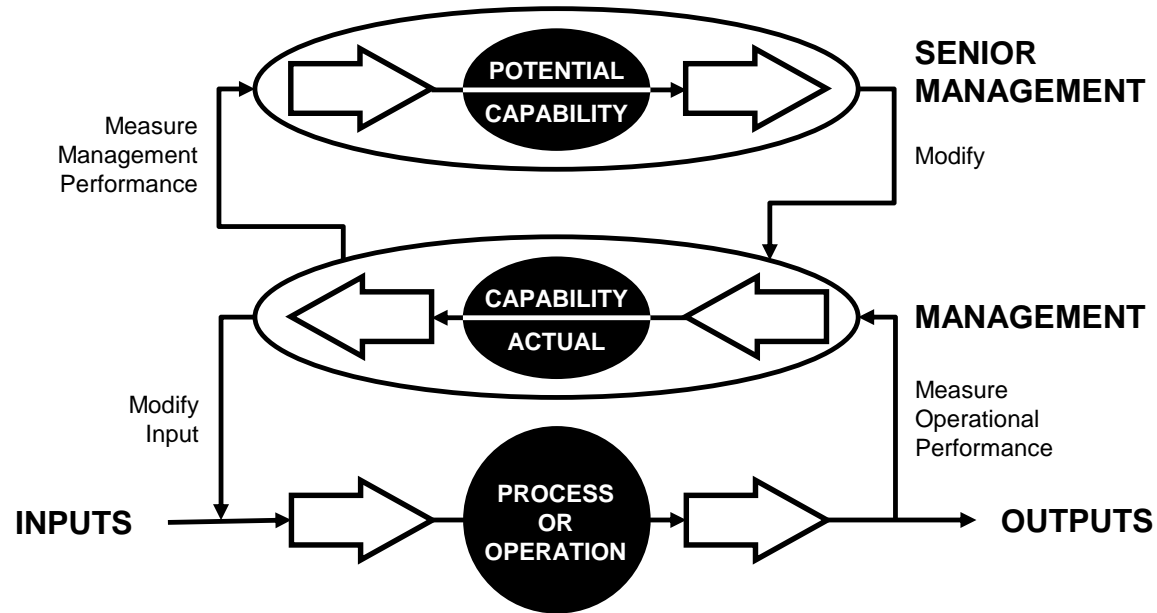

Fig 3.14 Senior Management Observing Management

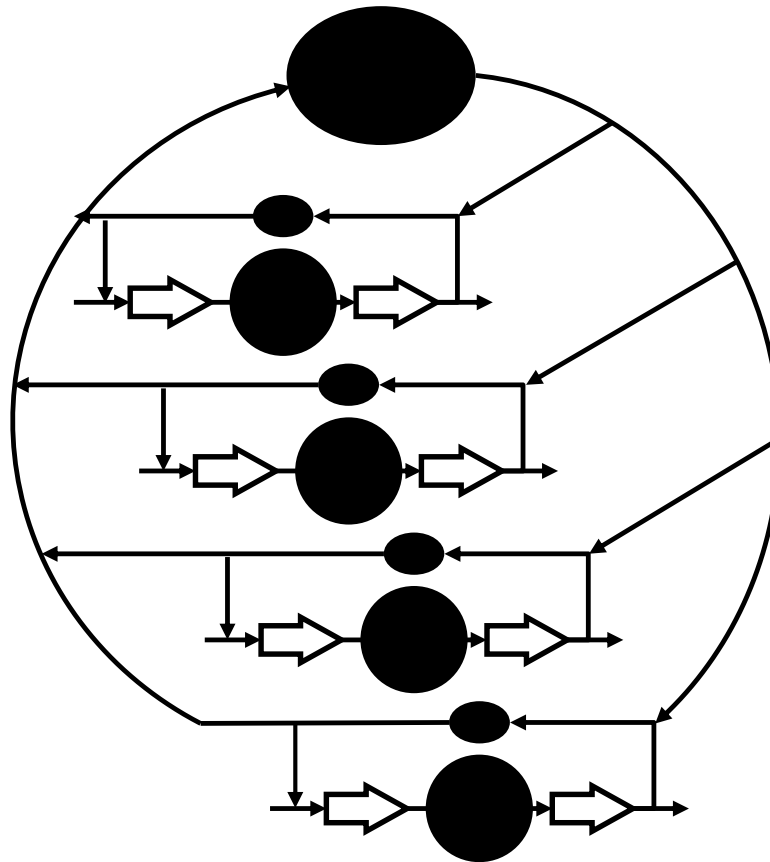

Fig 4.1 Fusion21 Conventional Hierarchy

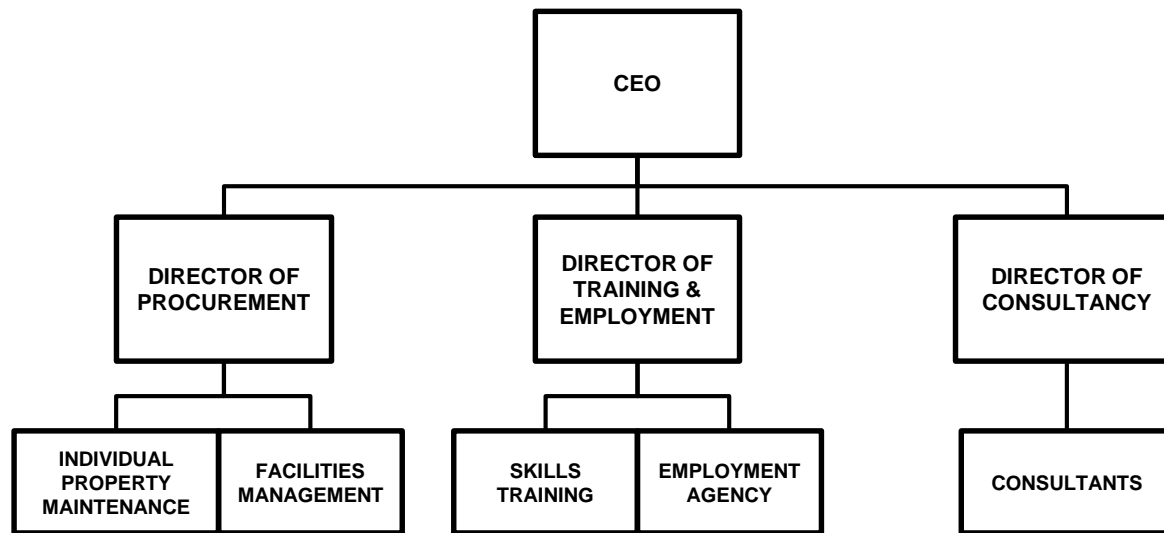

Fig 4.2 Fusion21 Process Perspective

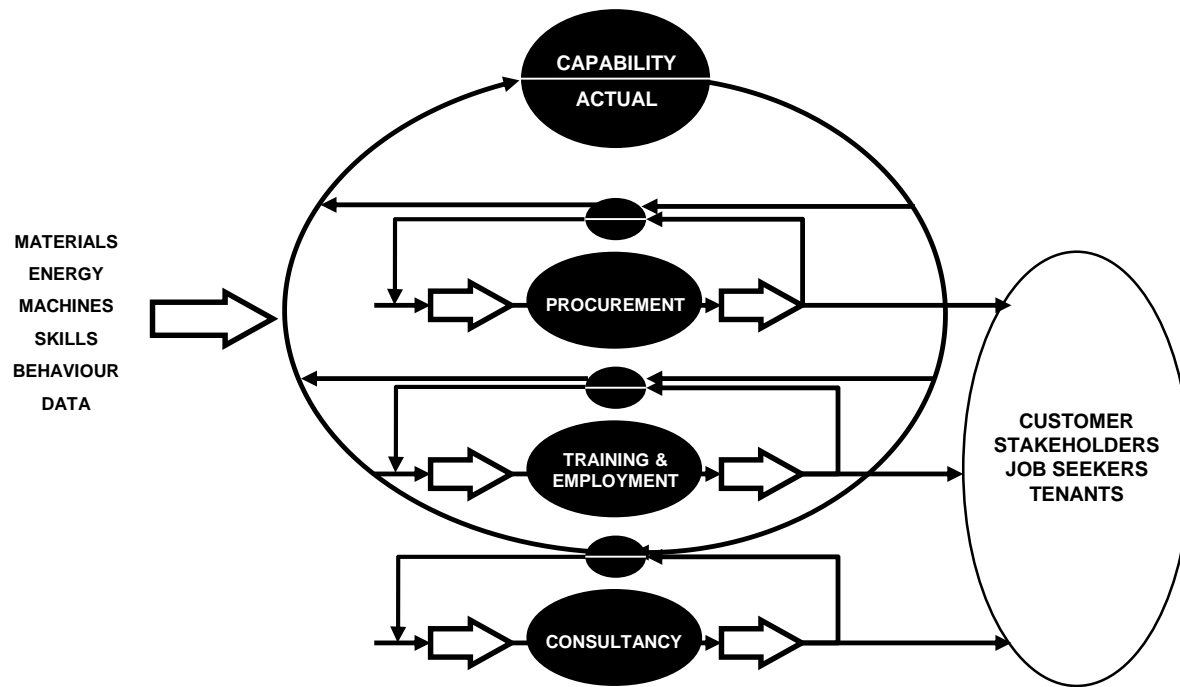

Fig 4.3 Fusion21 Embedded Tasks and Procedures

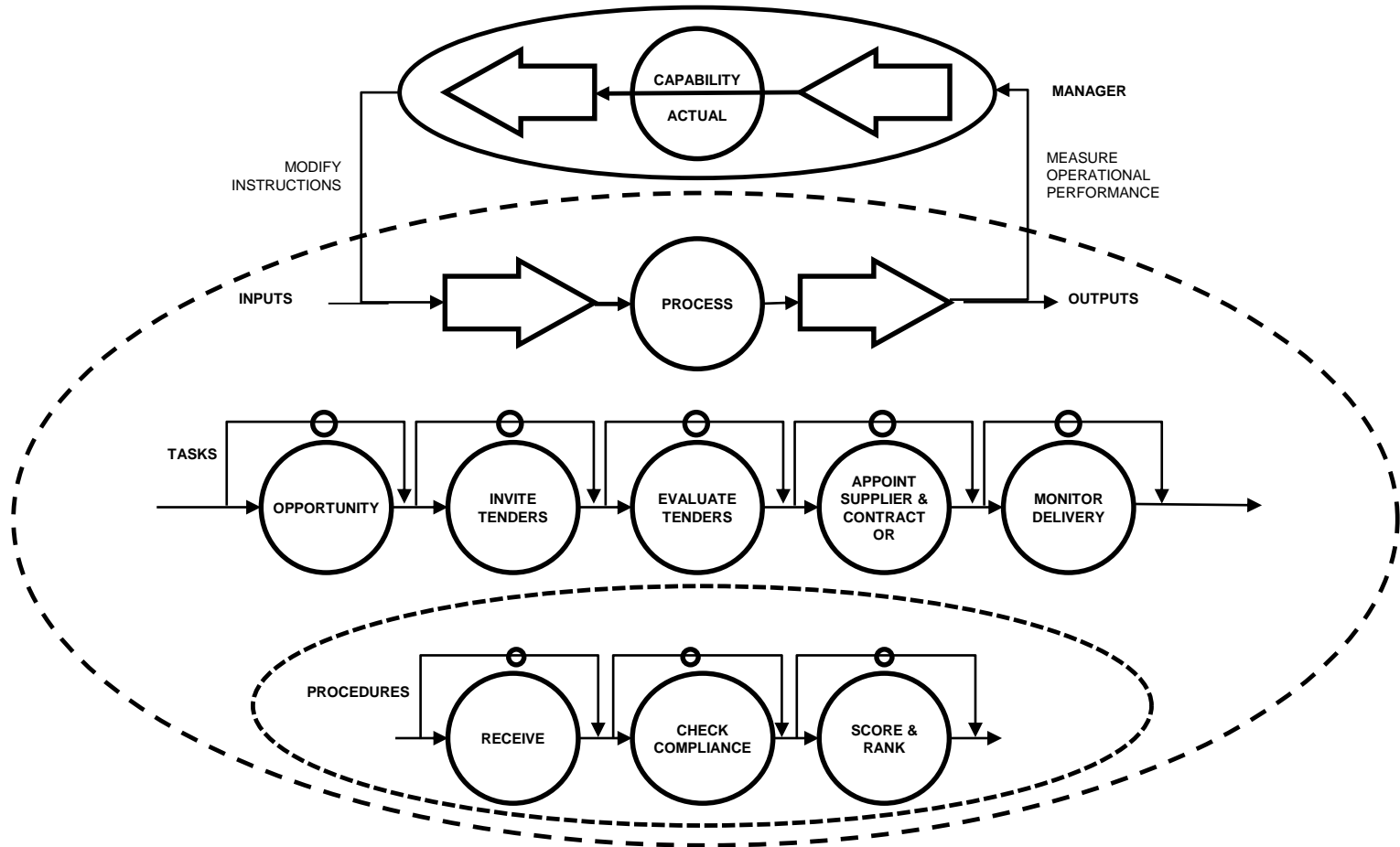

Fig 4.4 Fusion21 Procurement Workstreams

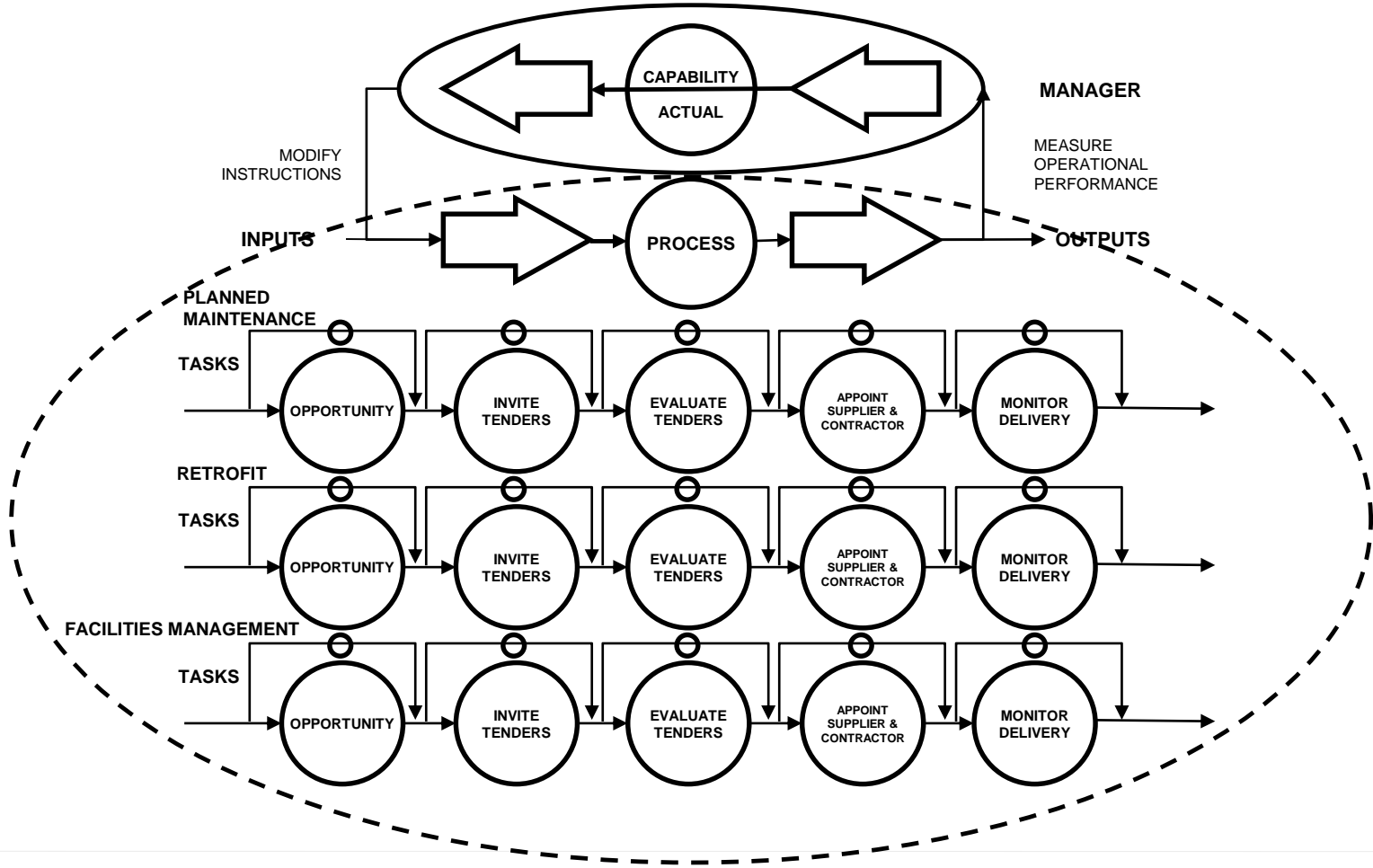

Fig 4.5 Canal and River Trust Virtuous Circle

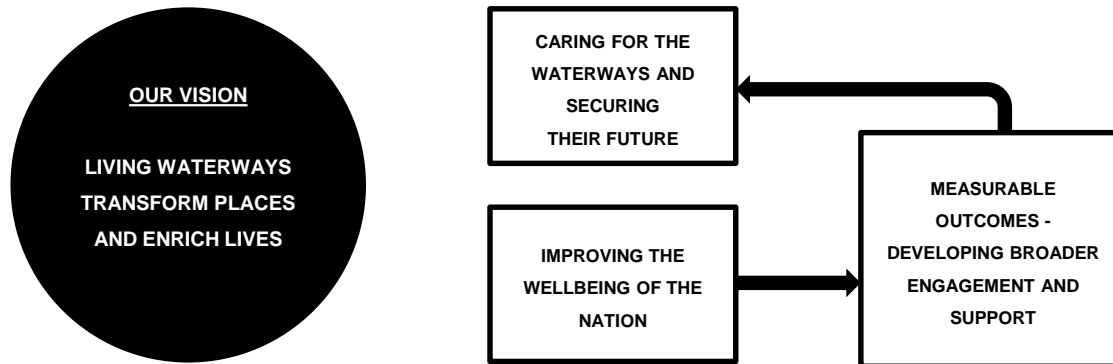

Fig 4.6 Canal and River Trust the Process Chain

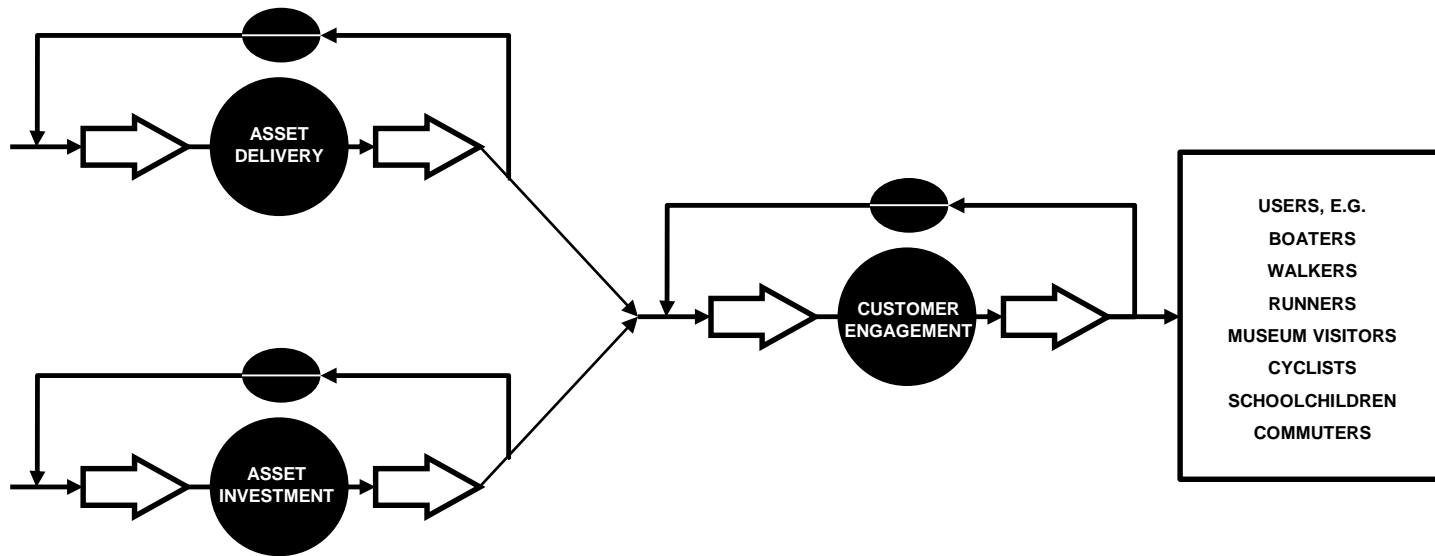

Fig 4.7 Canal and River Trust Processes with Embedded Tasks

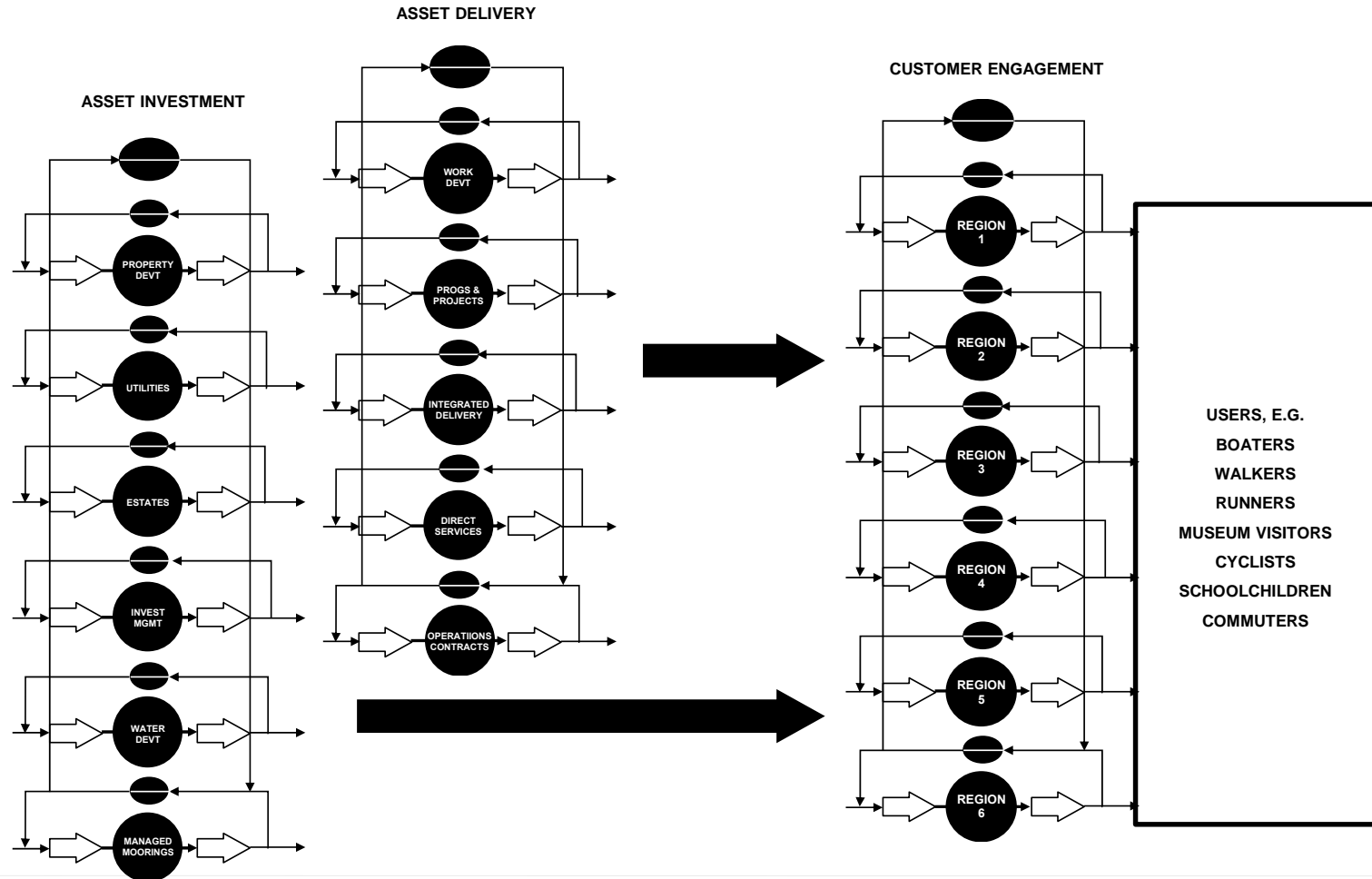

Fig 4.8 Southern Mill Organisation Chart

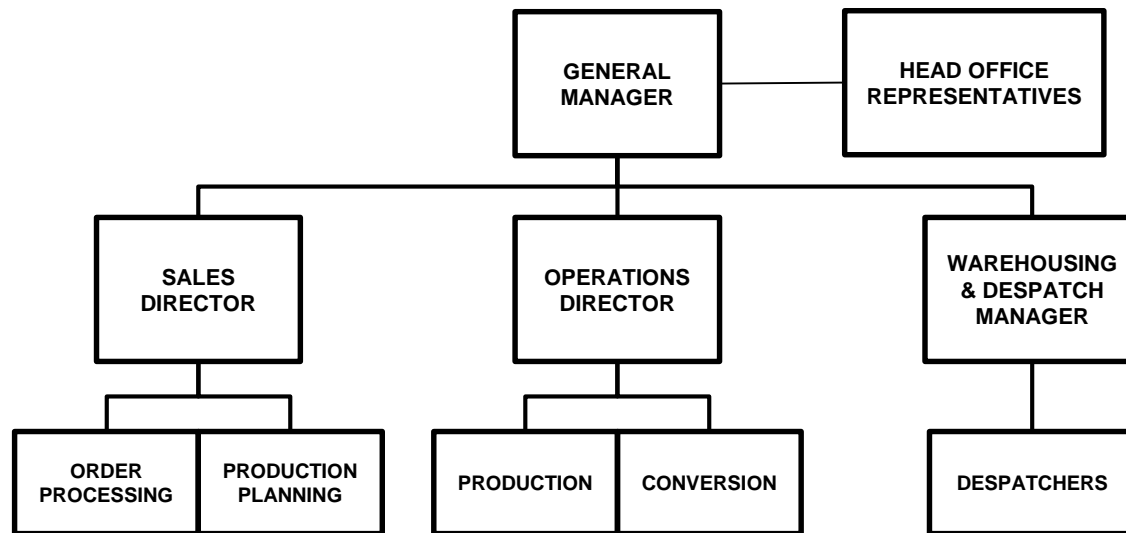

Fig 4.9 Southern Mill the Process View

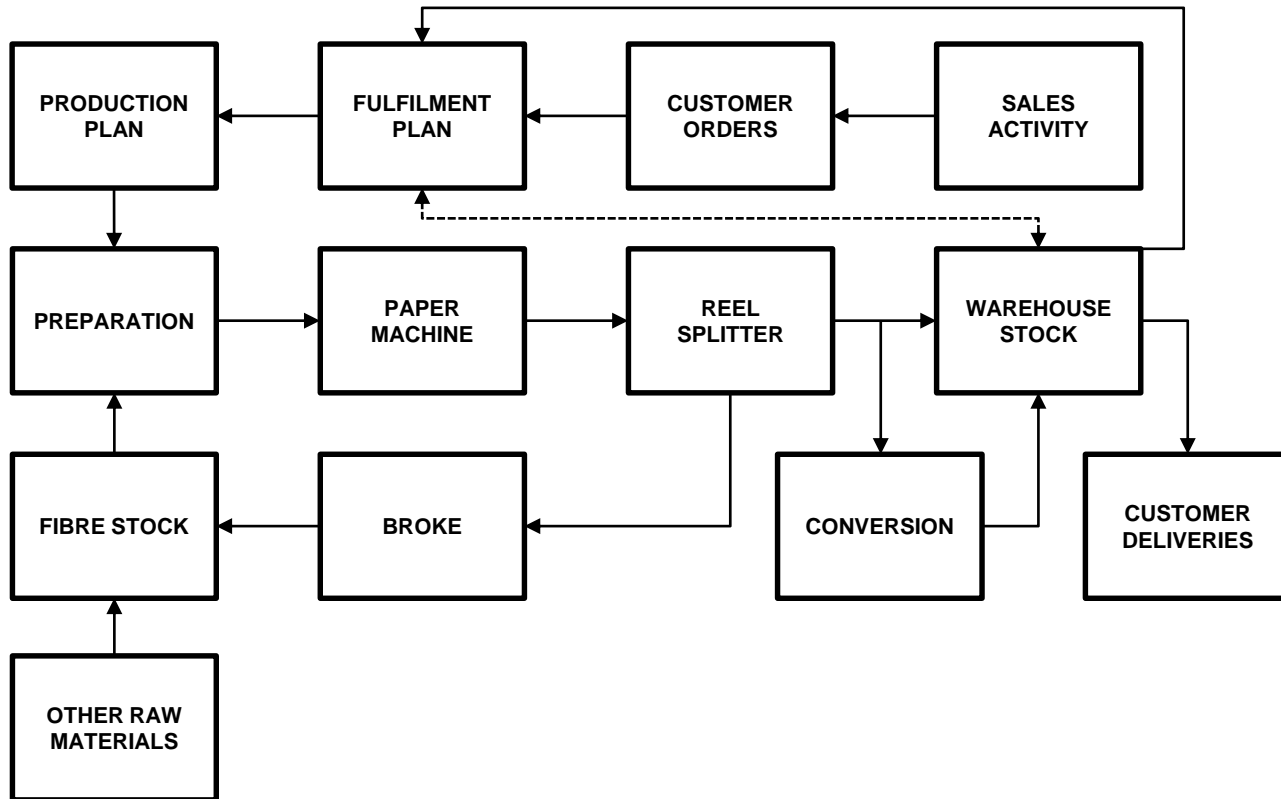
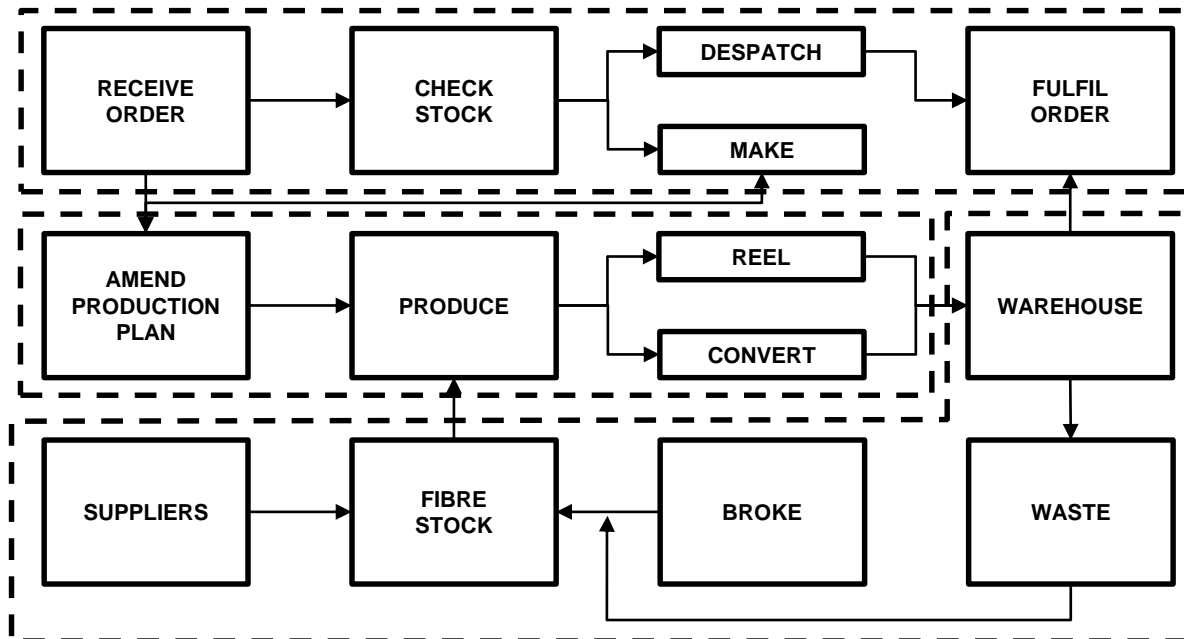
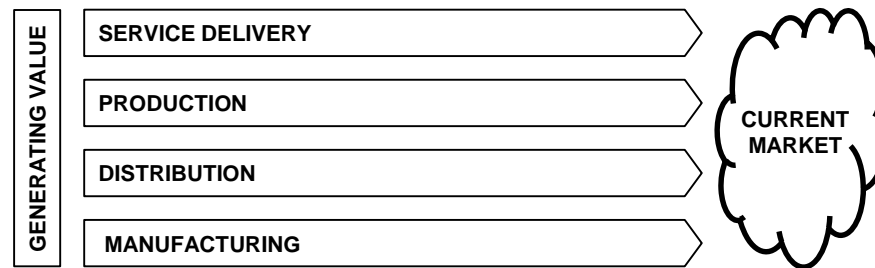
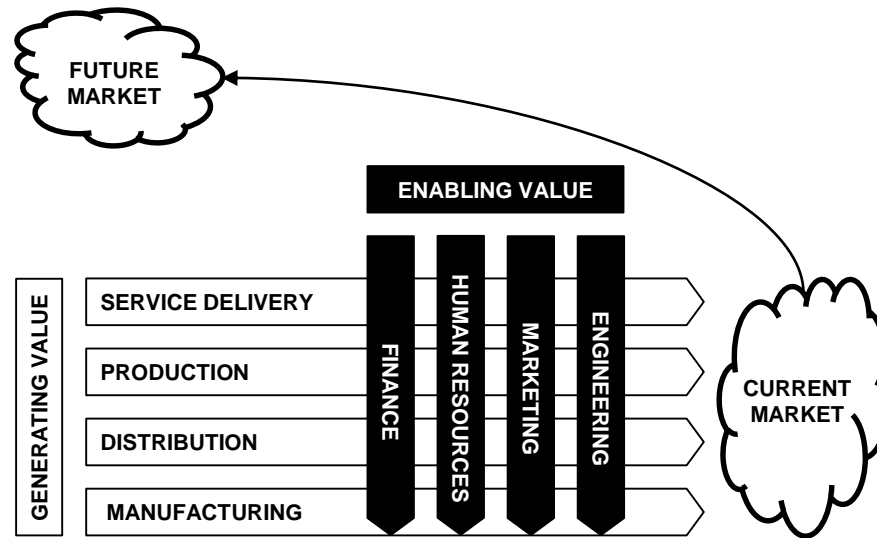

Fig 4.10 Southern Mill Key Processes



DAILY DASHBOARD: SOUTHERN MILL										
PRODUCTION			CONVERSION				SALES			
PLAN	ACTUAL	DIFF TO PLAN	PRODUCT	PLAN	ACTUAL	DIFF TO PLAN		PLAN	ACTUAL	DIFF TO PLAN
132	138	6	Sheeted	4	3	-1	Stock	600	630	30
Net Tonnes			Laminate	3	4	1	>180	0	45	45
Planned	Actual	Diff to Plan	Coated	2	2	0	>365	0	0	0
80	100	20	Colour	1	1	0	Despatch	104	100	-4
Hold	Over-make	Broke	Coiled	1	1	0	OTIF	98%	96%	-2%
20	50	5	Coiled SS	2	3	1	Orders	100	105	5
Shut			Collated	3	2	-1	Rev	£90000	£94500	£4500
Plan	Unplan	Diff to Plan	Guillotine	5	5	0	Credits	£0	£3000	£3000
48	56	8	BPOP	6	6	0	Unplan £	0	£500	£500
			Packed FP	4	4	0	Complaints	0	1	1
			Packed BP	5	5	0	Accidents (LT)	0	1	1





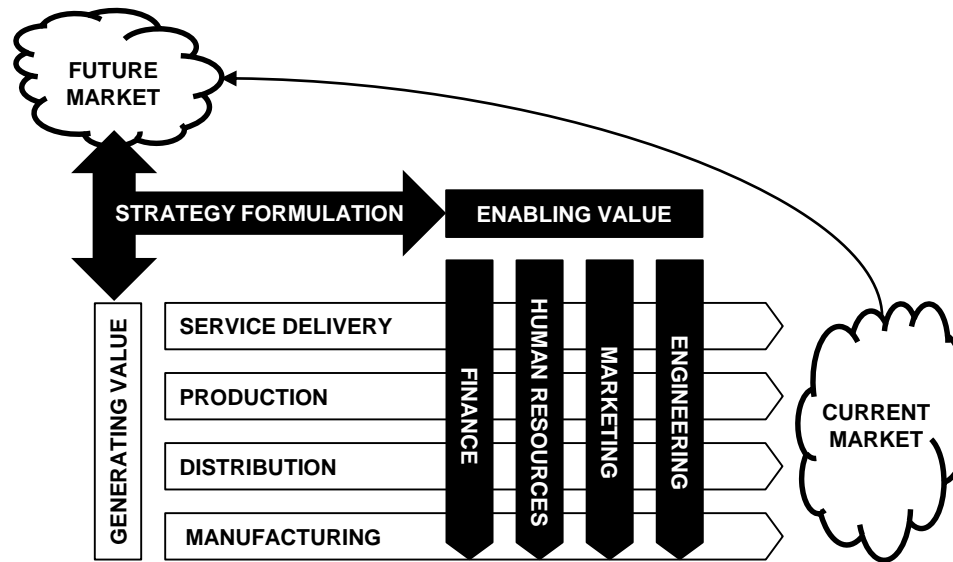

Fig 5.4 Value Enabling Process

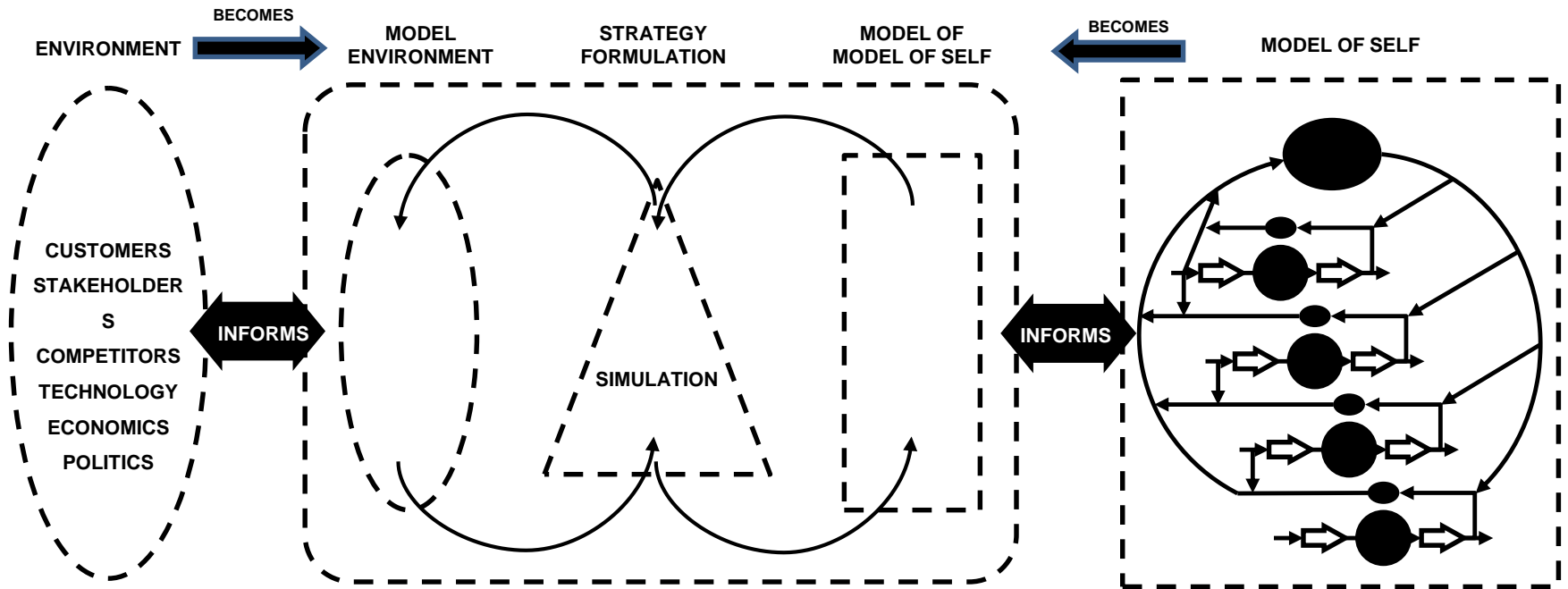

Fig 5.5 Enabling Value interacting with Generating Value

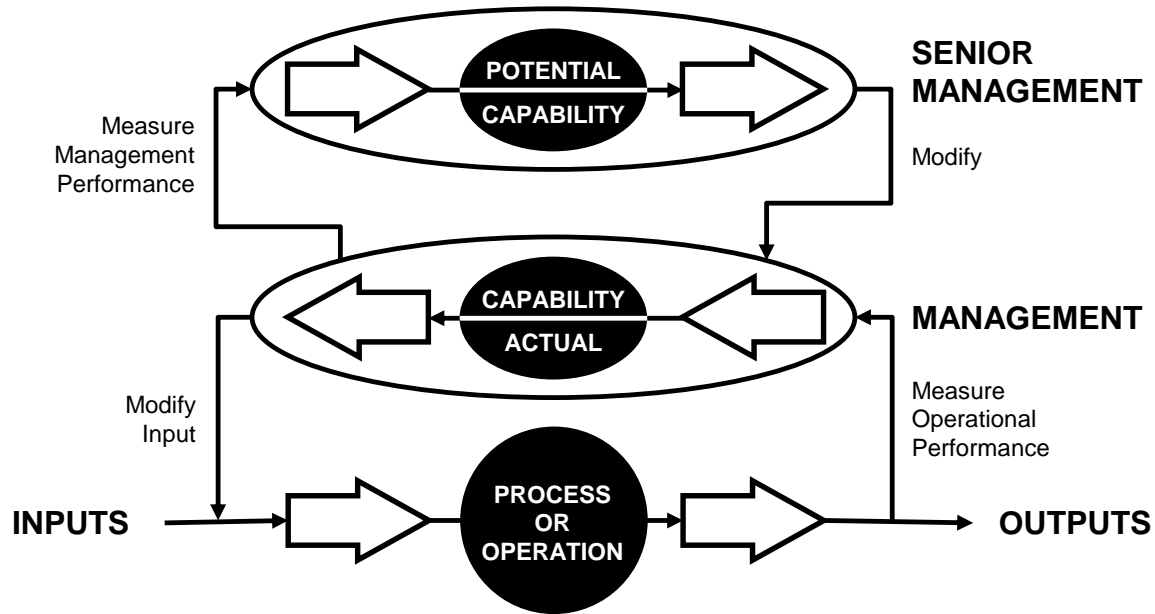

Fig 5.6 The Multi-Channel Value Enabling Process

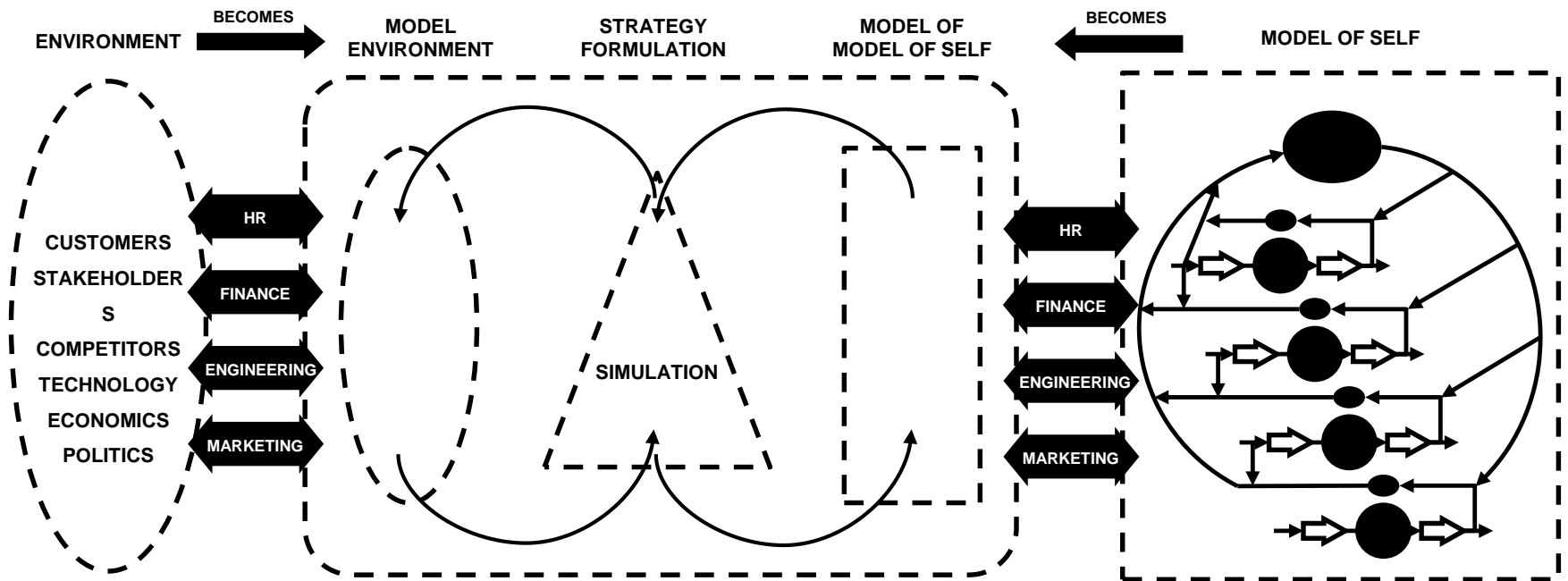
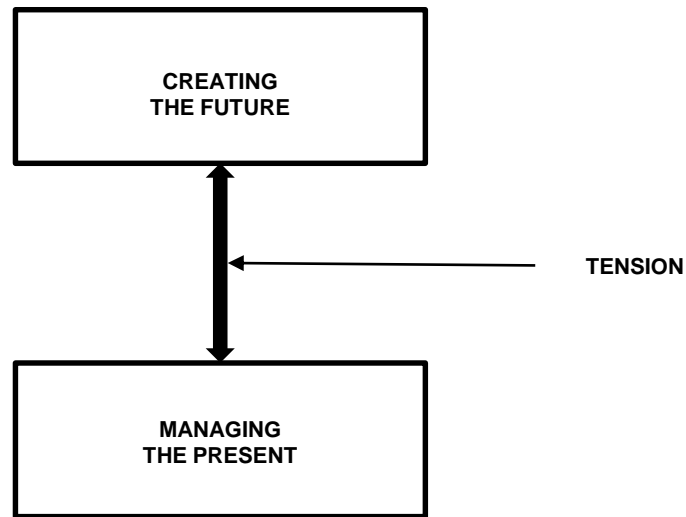

Fig 5.7 Managing the Present and Creating the Future



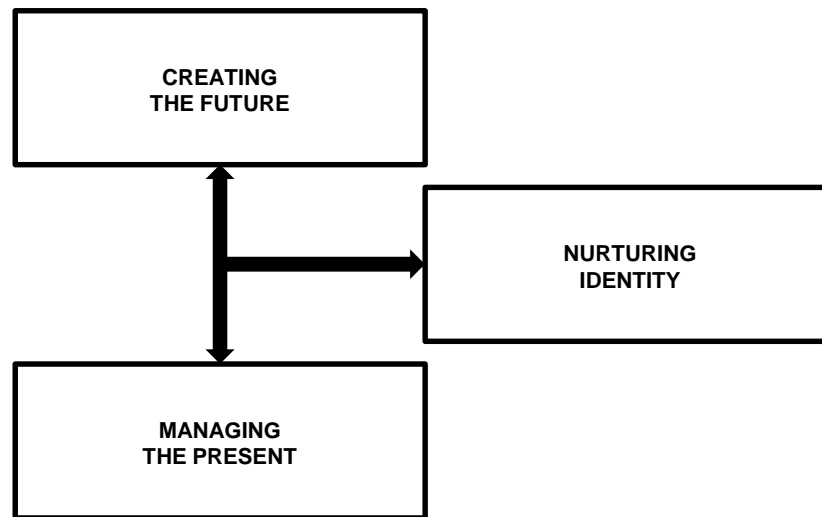

Fig 5.9 The Intelligent Organisation

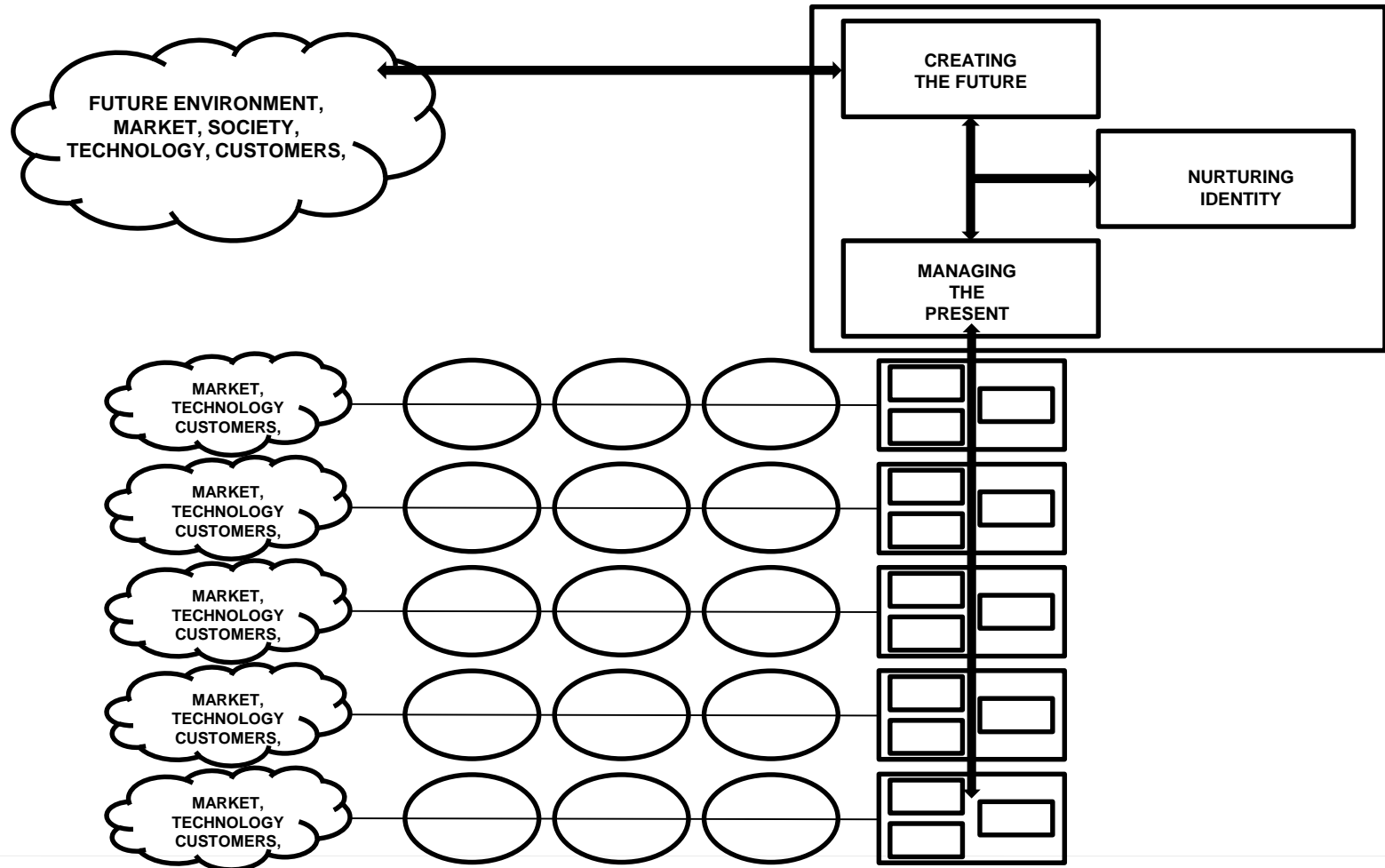

Fig 6.1 Enabling Value for Fusion21

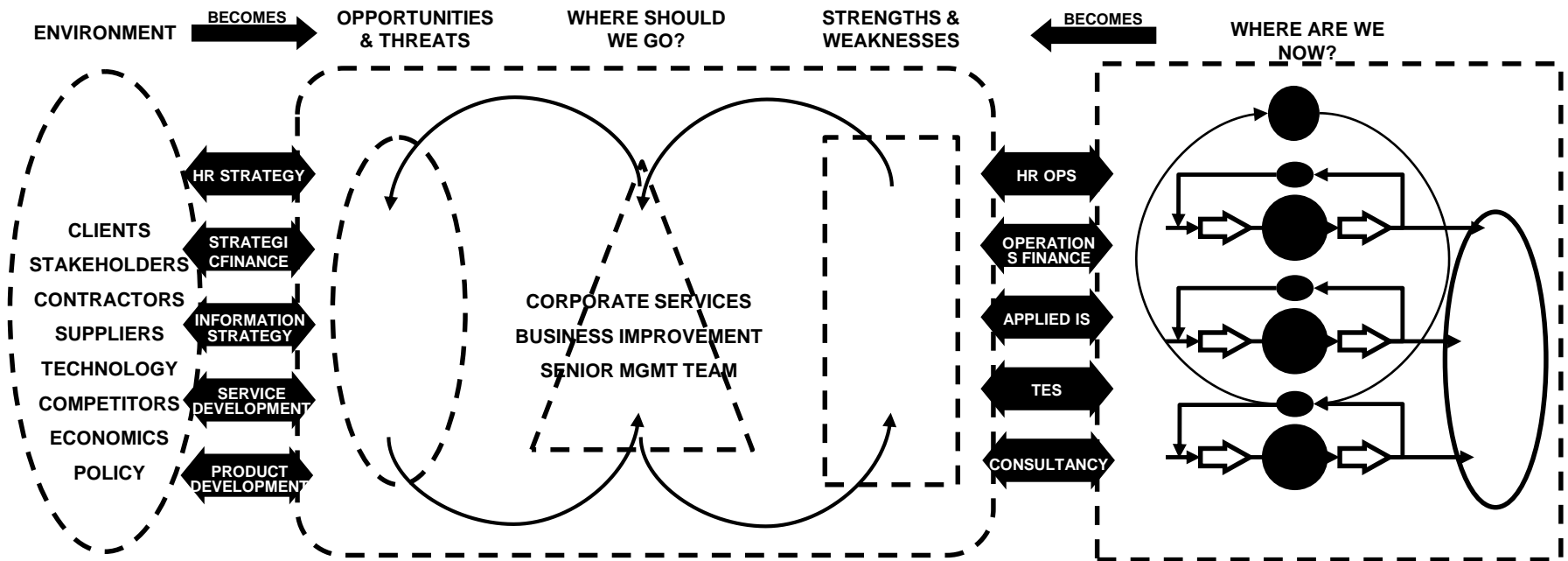

Fig 6.2 – The Strategic Dialogue

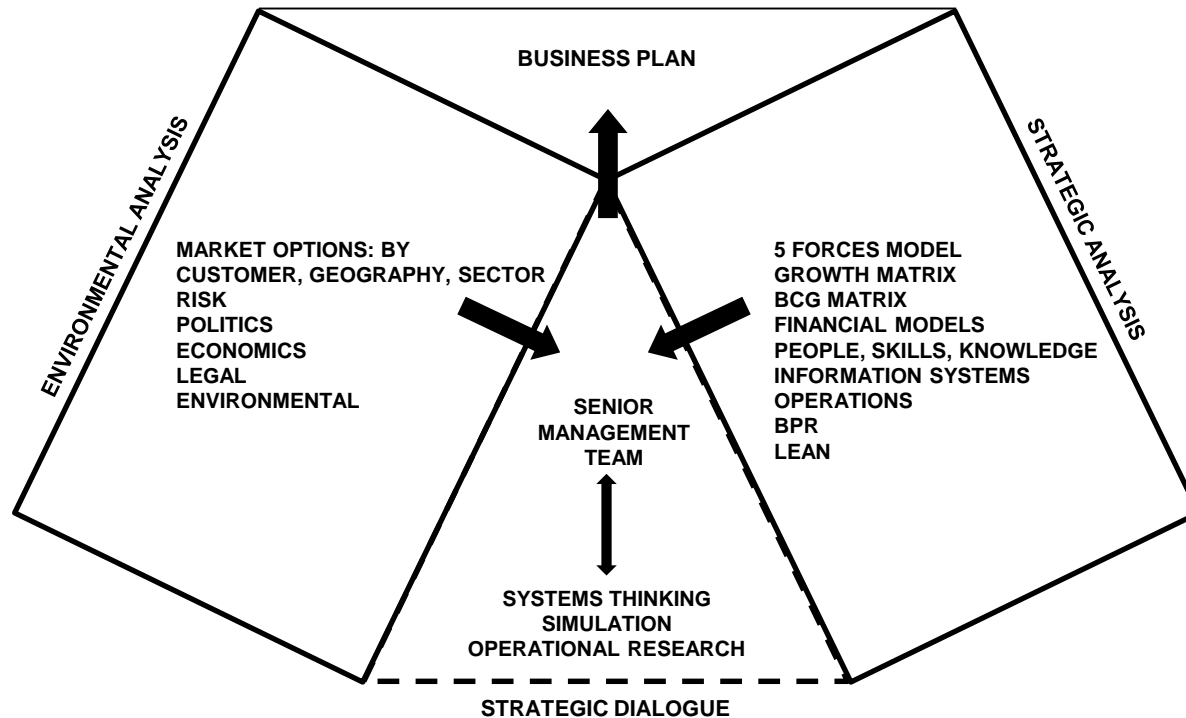
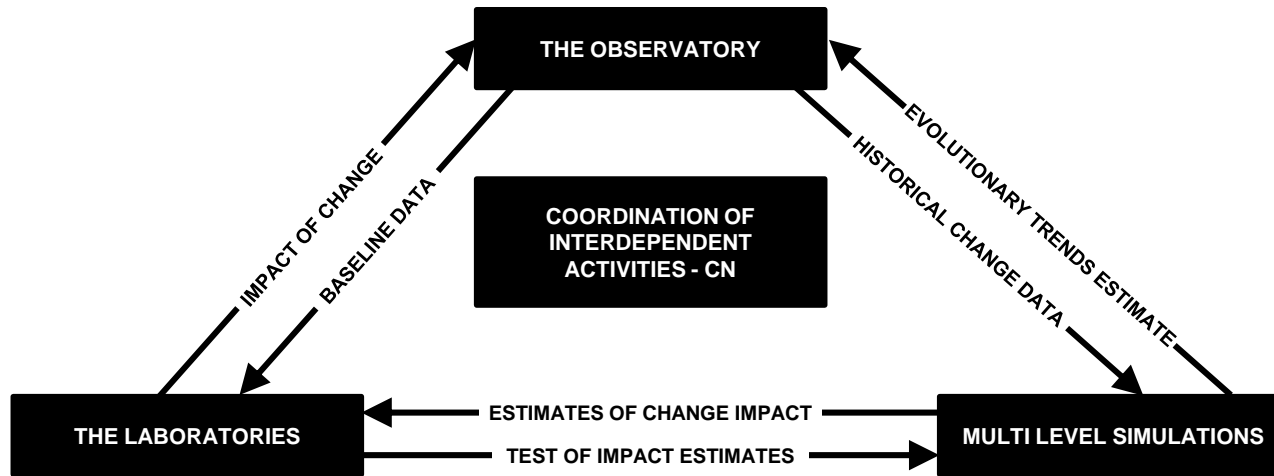

Fig 6.3 Initial Executive Information Requirements

CHIEF OPERATING OFFICER	CHIEF INVESTMENT OFFICER	STRATEGY & ENGAGEMENT DIRECTOR	ASSET IMPROVEMENT DIRECTOR	FINANCE DIRECTOR	HR DIRECTOR
PROGRESS V OBJECTIVES	ASSET PRODUCTIVITY	OUTCOMES V OBJECTIVES	DIRECT SERVICES PRODUCTIVITY & UTILISATION	FINANCIAL CONTROL	HEADCOUNT & SKILLS/TRAINING PERFORMANCE
PRODUCTIVITY	LONG TERM ROI	DONOR & SUBSCRIBER INFORMATION	COMPLIANCE TO STANDARDS	STATUTORY OBLIGATIONS	ABSENCE, SICKNESS, GRIEVANCES
ATTRACTIONS PERFORMANCE	IN-YEAR PERFORMANCE	COMMUNITY ENGAGEMENT	PERFORMANCE VERSUS PLAN	MANAGEMENT REPORTING	SAFEGUARDING
CUSTOMER CONCERNS	CAPITAL ACCUMULATION	COMPLIANCE WITH STATUTORY OBJECTIVES	PROJECT PERFORMANCE – TIME, COST, QUALITY	INFORMATION SYSTEMS PERFORMANCE	EMPLOYEE PERFORMANCE
ASSET PERFORMANCE	LETTABLE ASSETS PERFORMANCE	INFORMATION FOR THE TRUSTEE DAHSBOARD	ASSET CONDITIONS & PERFORMANCE	RISK & CONTINUITY	TRAINING & DEVELOPMENT
VOLUNTEERING	MUSEUMS	VOLUNTEERS	VOLUNTEERS	AUDIT	GRIEVANCE AND COMPLAINTS



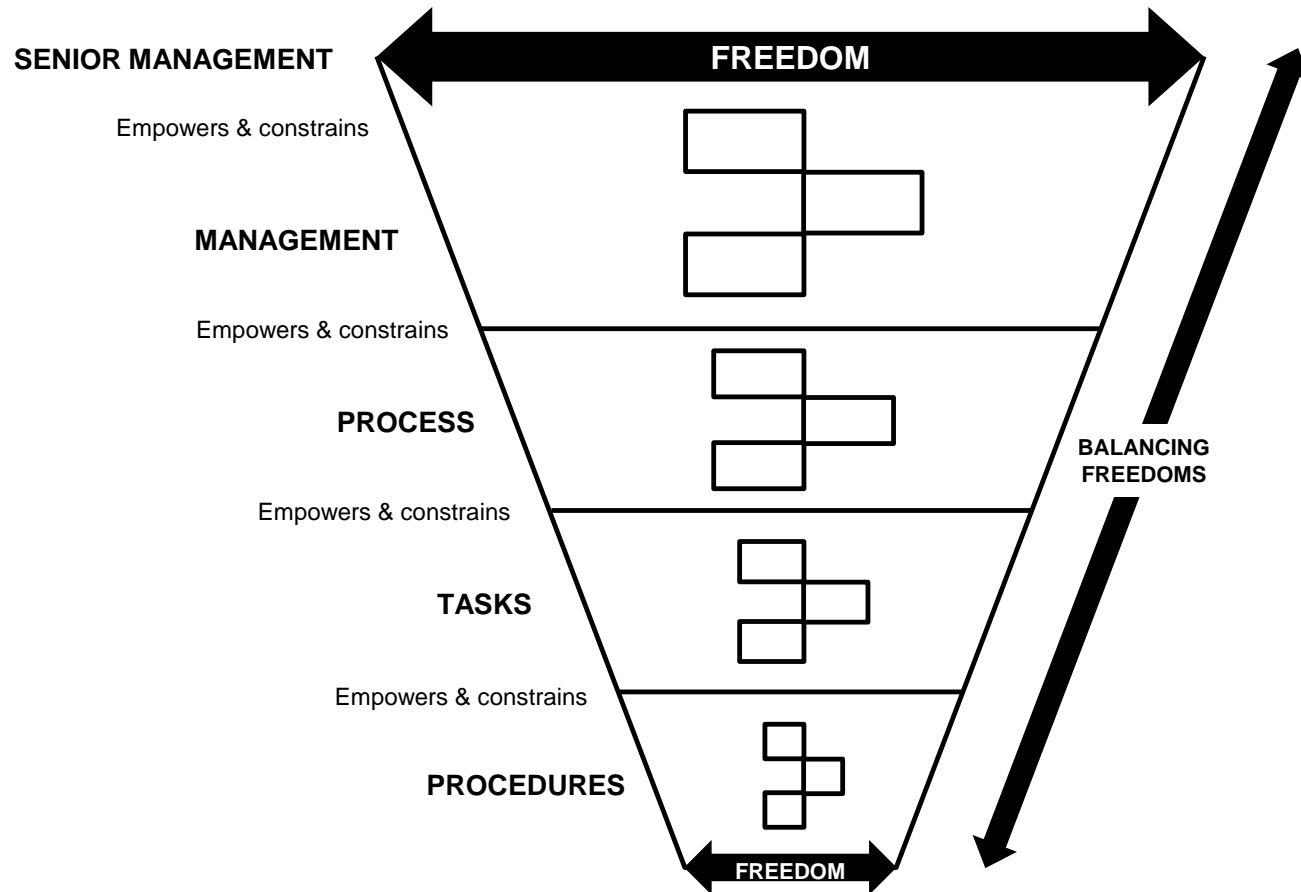

Fig 7.2 The Business Model

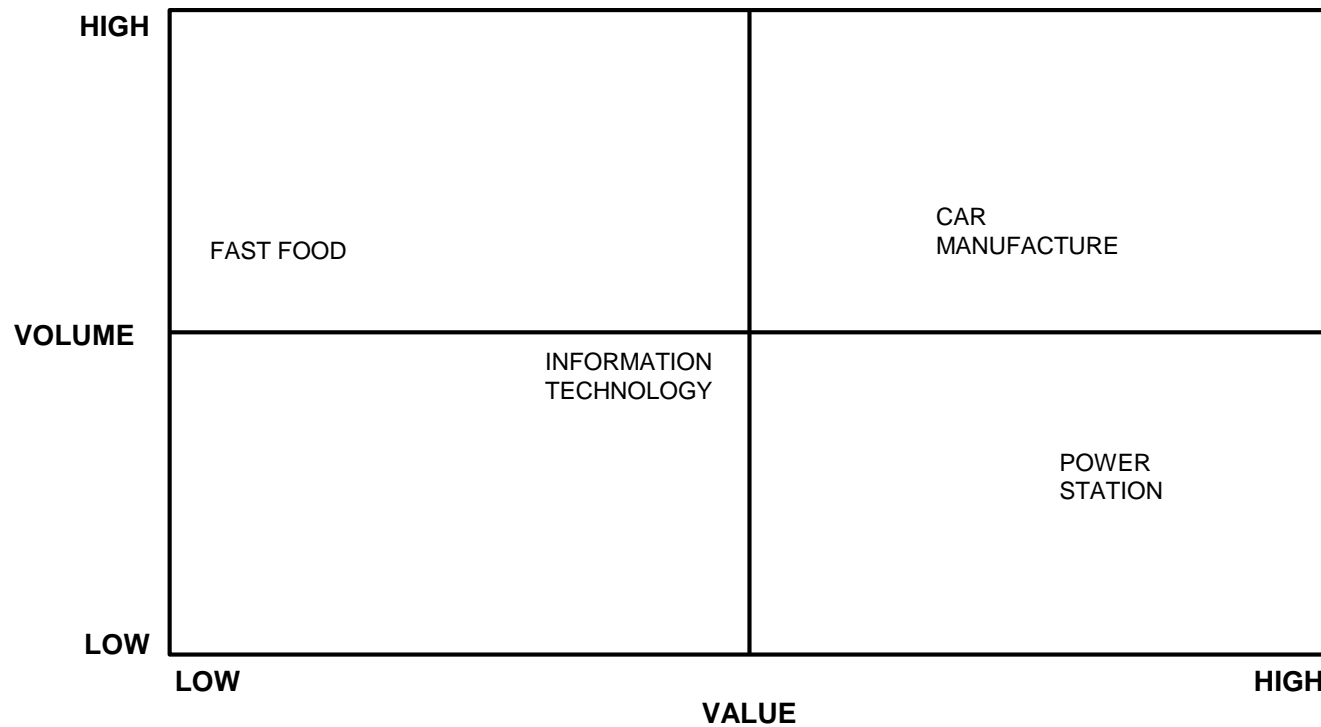

Fig 7.3 Process Progression

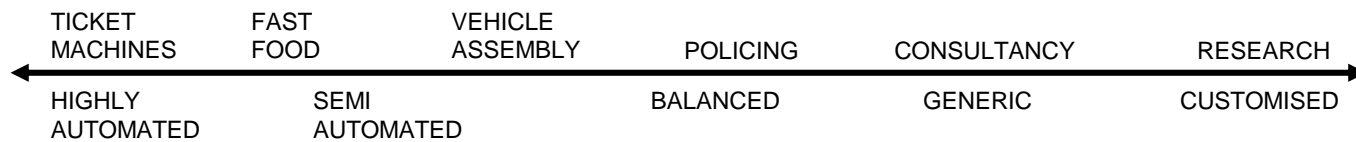

Fig 7.4 Skills Progression

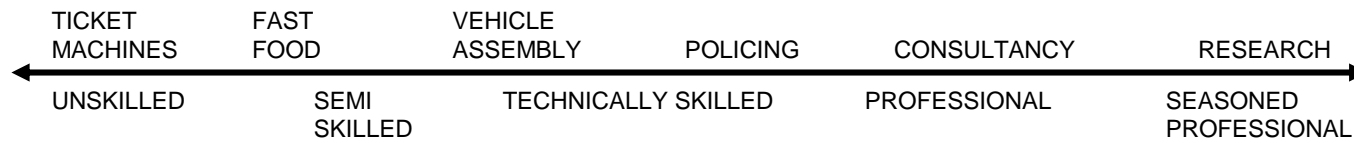
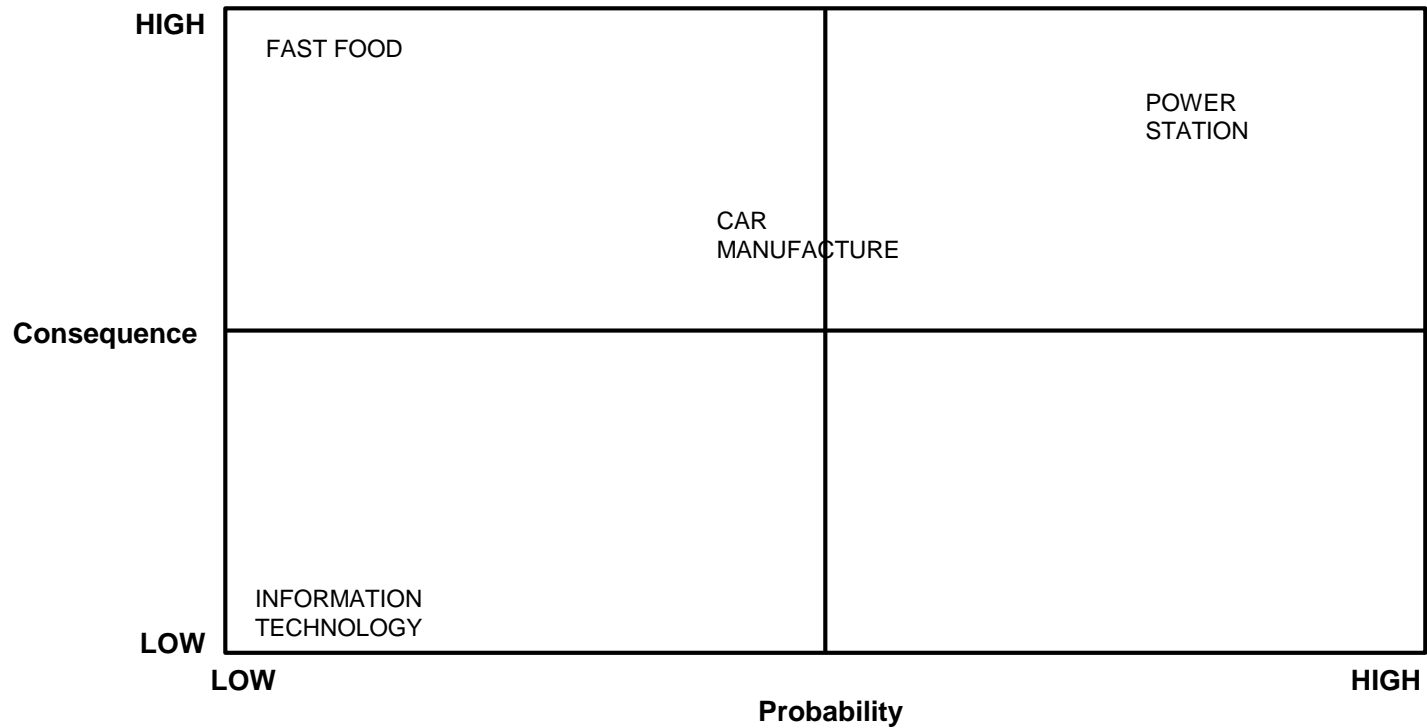

Fig 7.5 Risk, Probability and Consequence



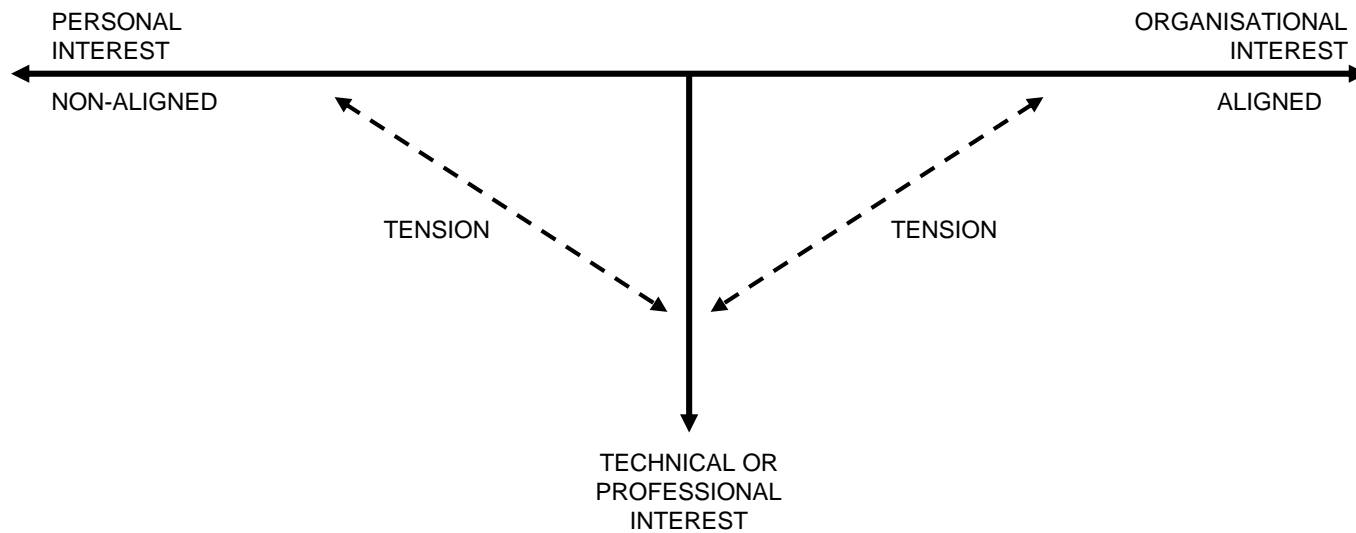
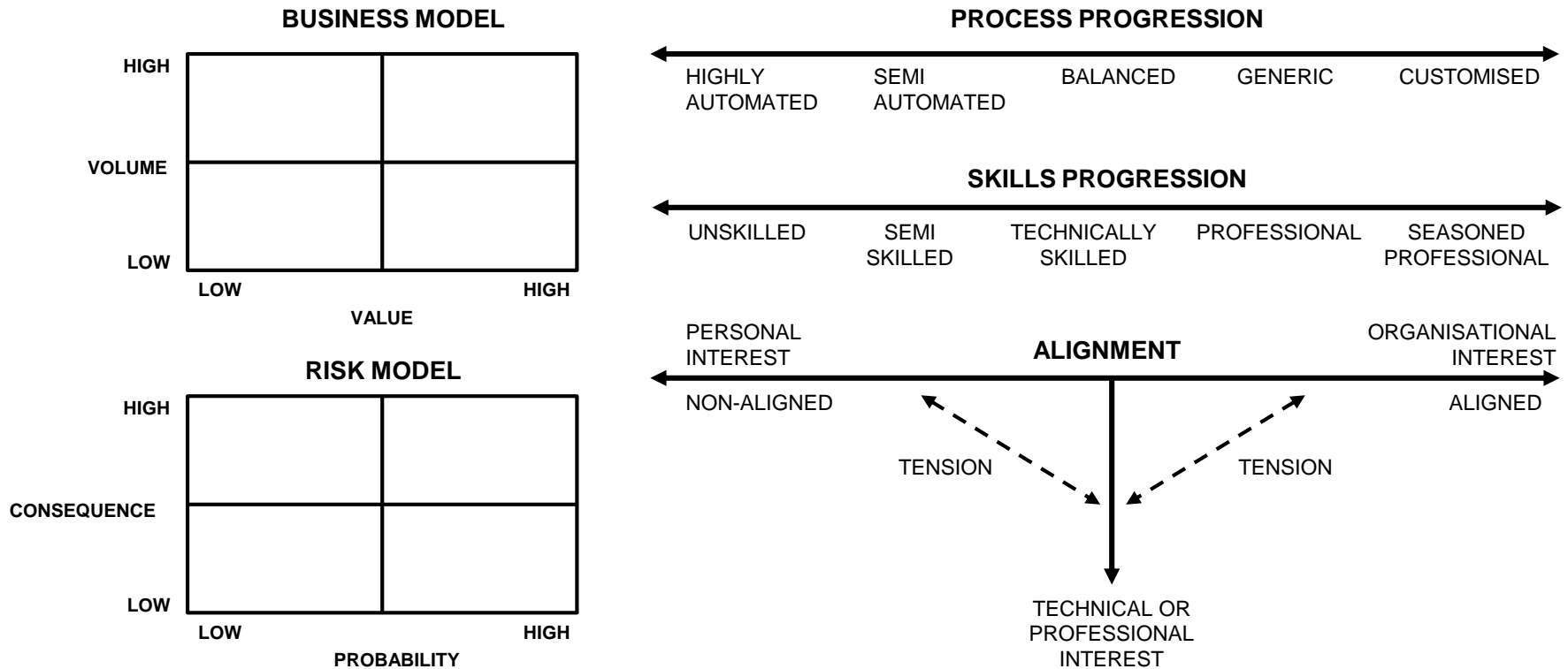

Fig 8.1 Integrated Decision Model for Autonomy



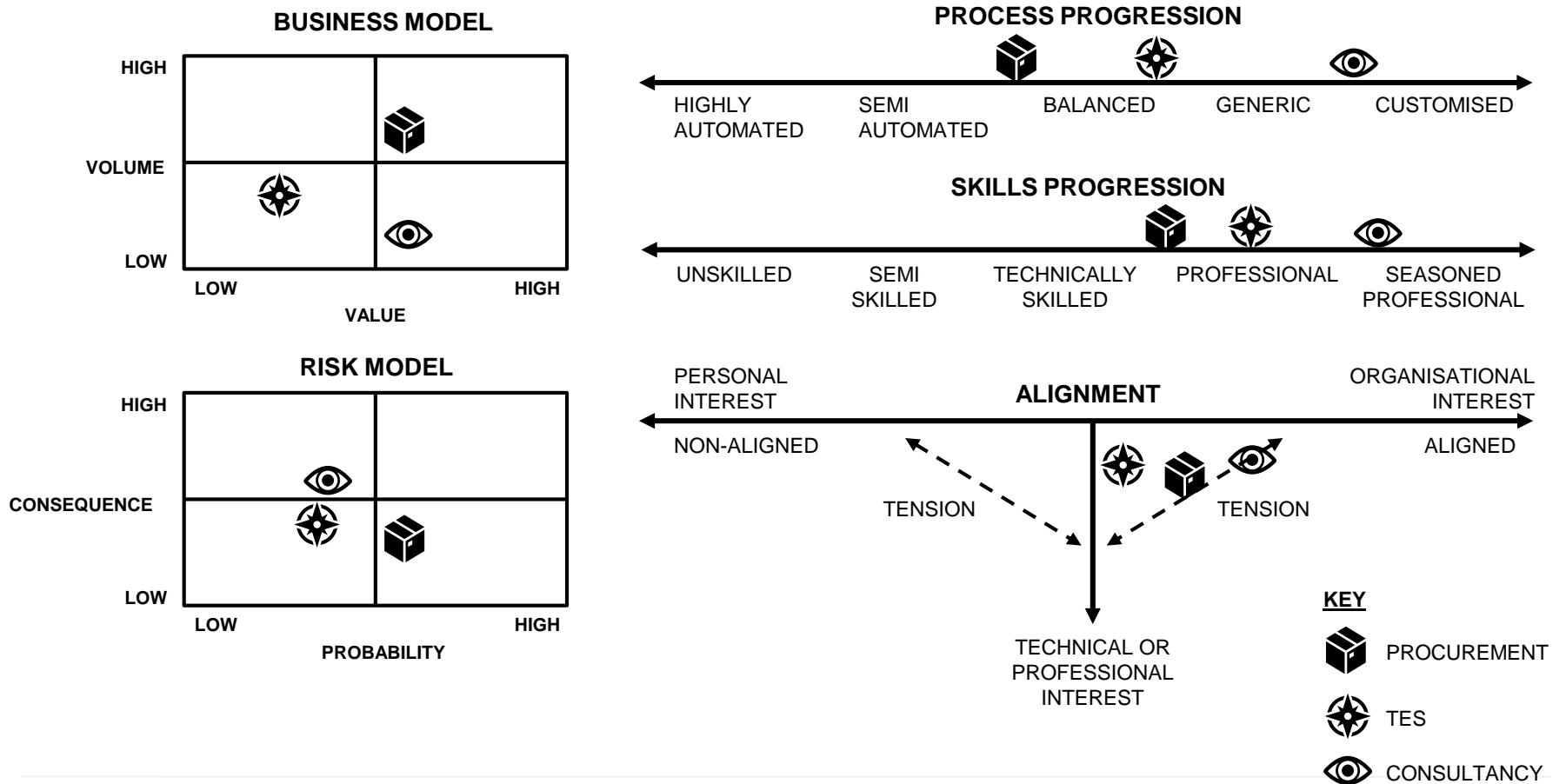

Fig 8.3 Necessary and Constrained Autonomy Canal and River Trust

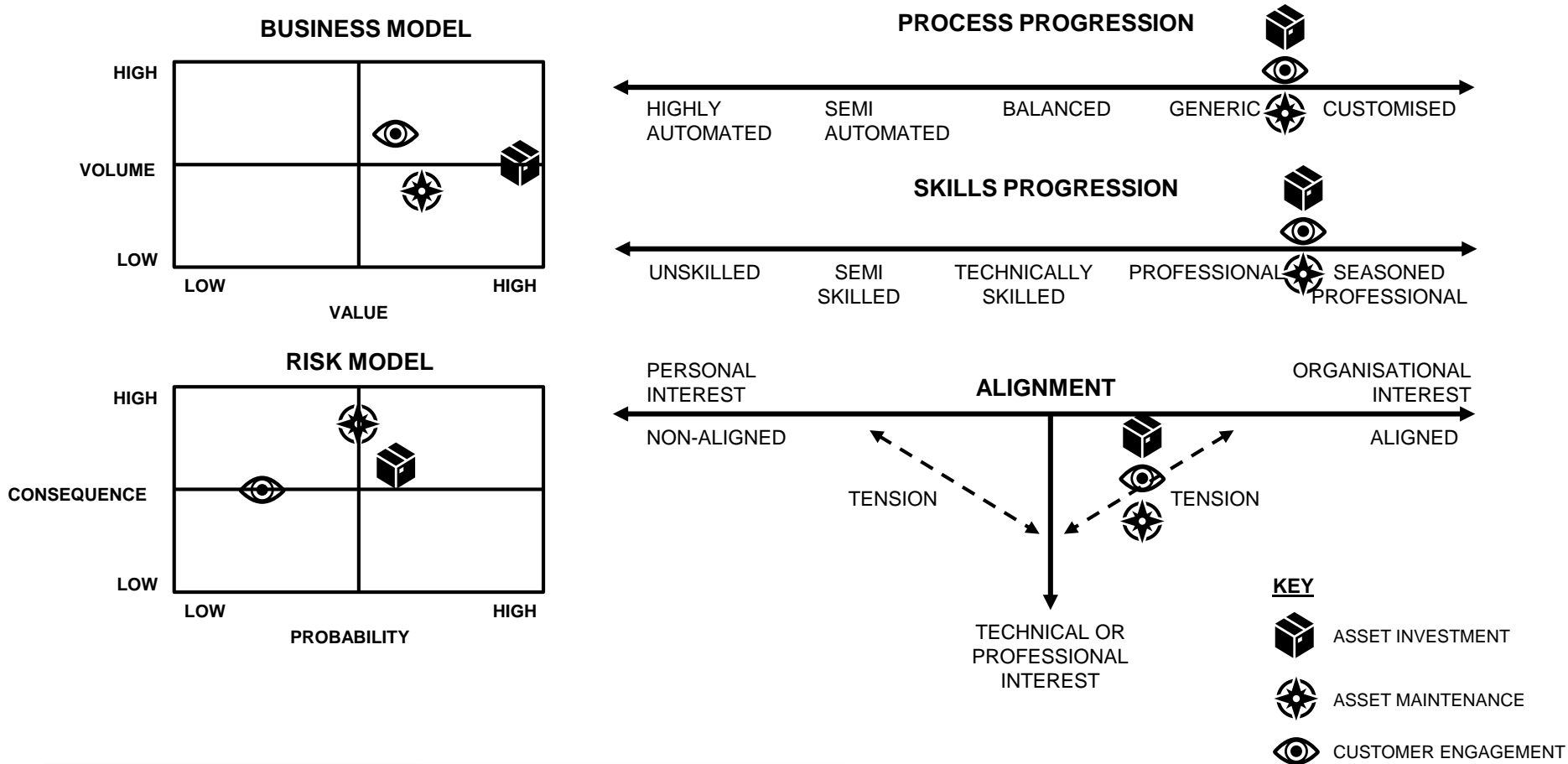

Fig 8.4 Autonomy in Southern Mill

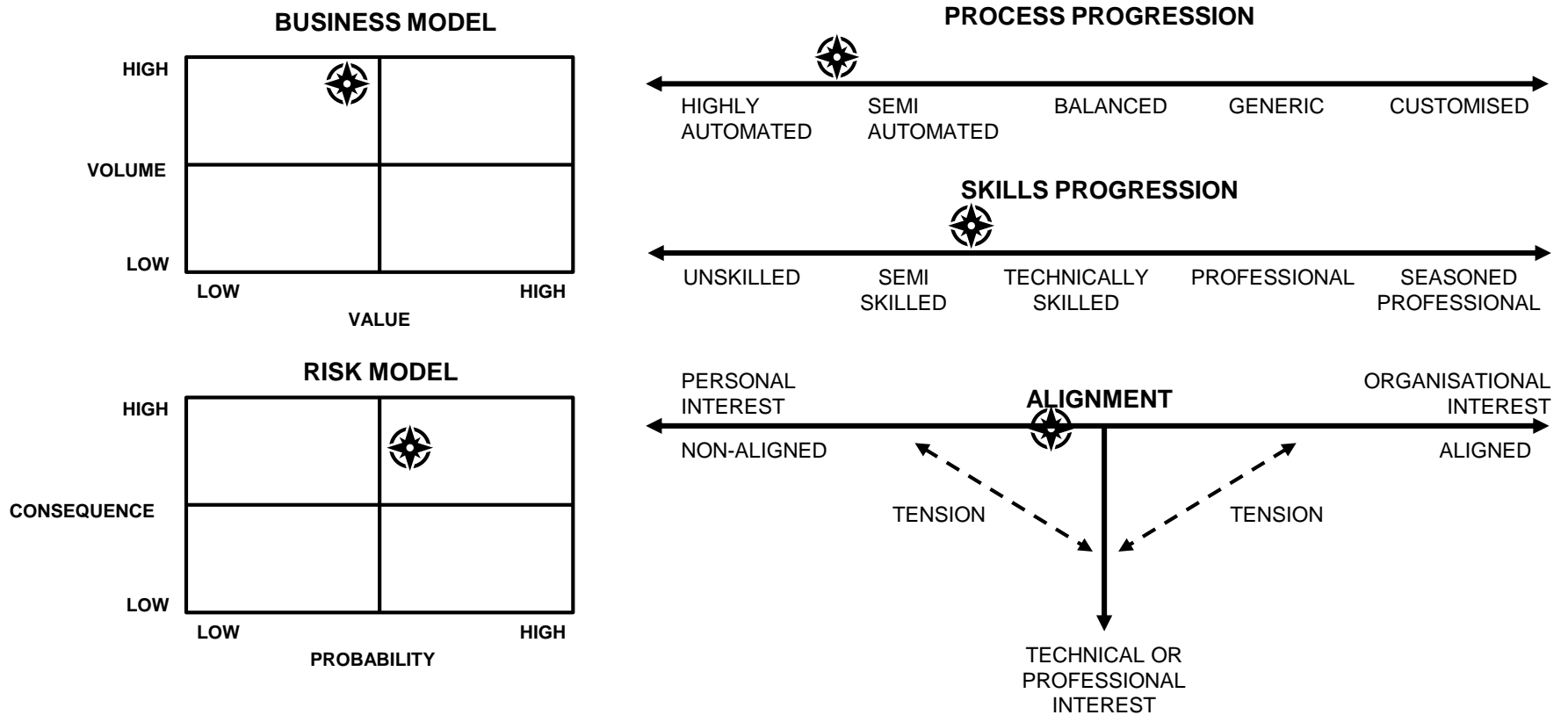
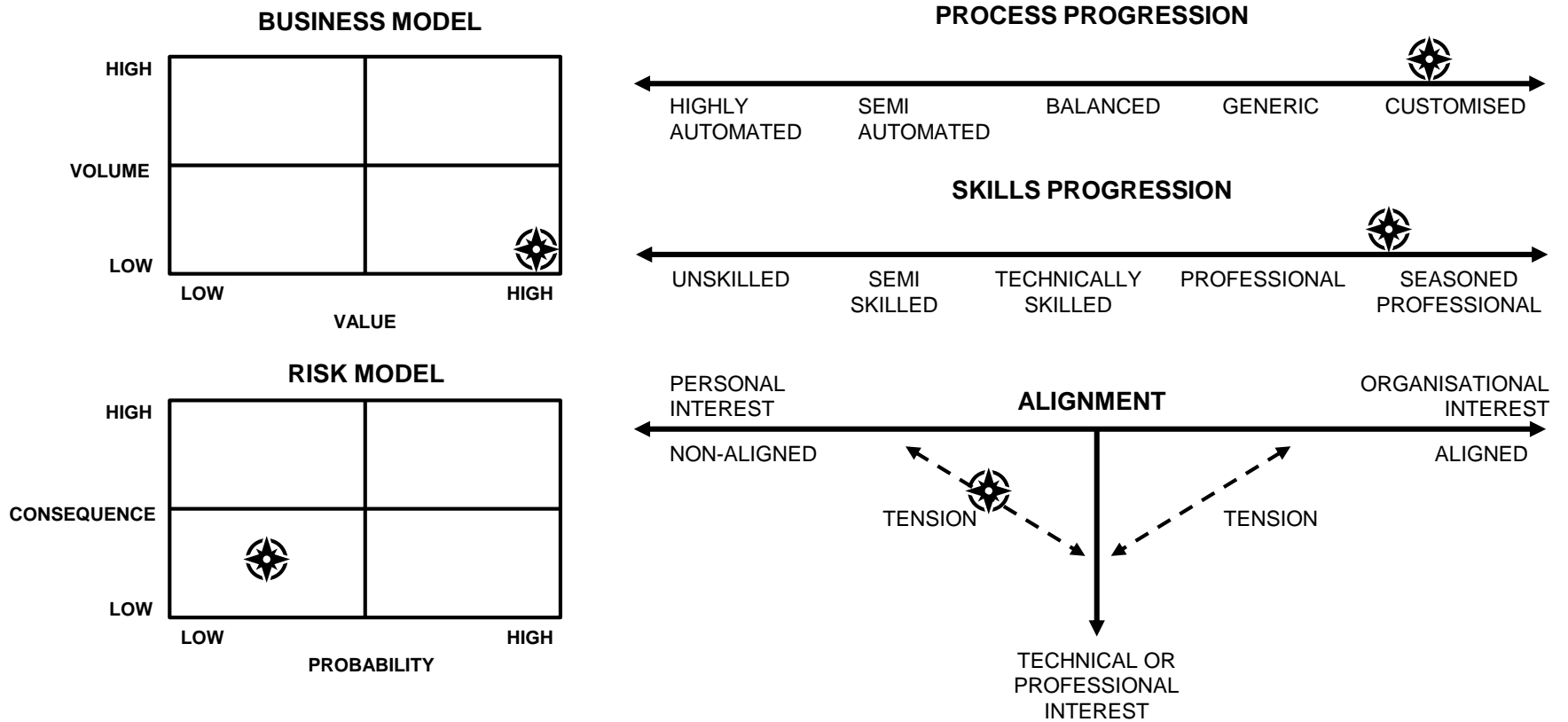

Fig 8.5 Autonomy in UKCRIC



KEY
 ACADEMIC

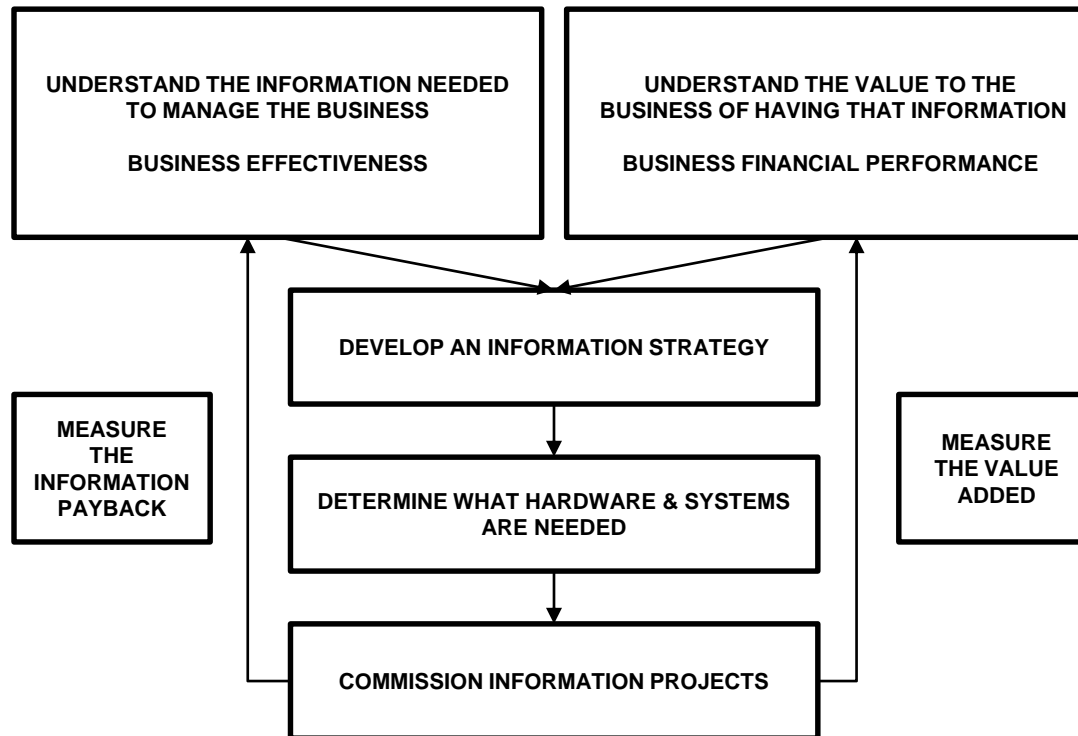
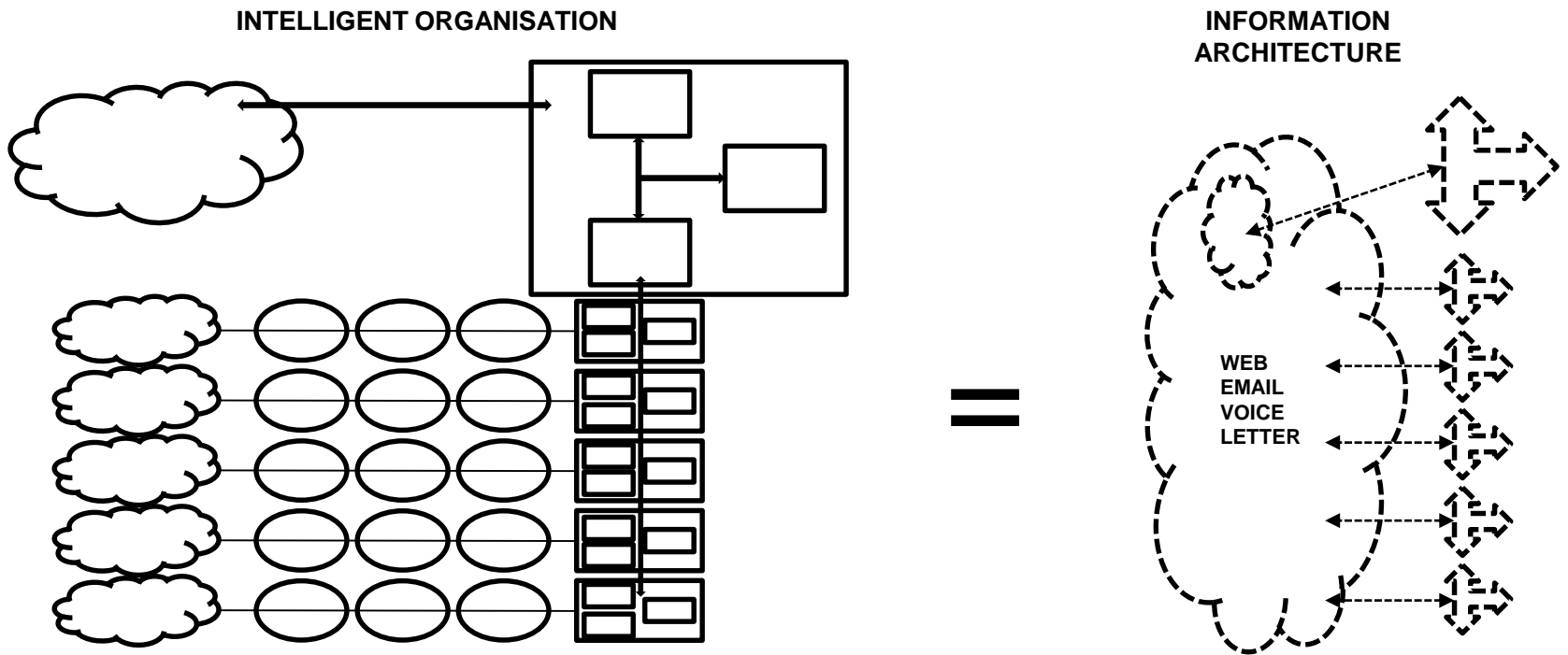
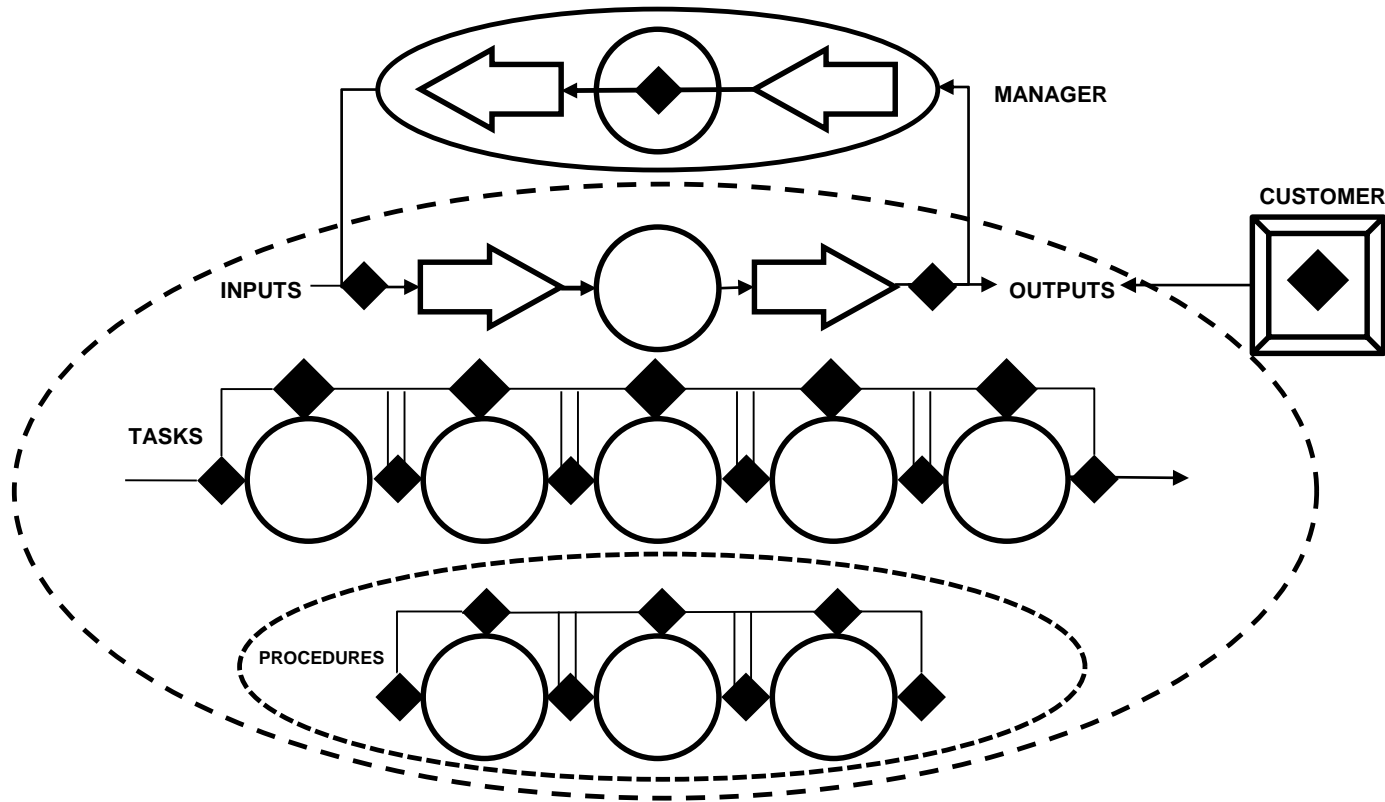

Fig 9.2 Mapping Organisation and Information Architecture





**Fig 9.4 A Performance Dashboard
for a Paper Maker**

PROCESS PERFORMANCE													
INPUT		39656		TARGET		40000		OUTPUT		36664.22			
	POTENTIAL	UNIT CAPABILITY	PROCESS CAPABILITY	MOST LIKELY	UNIT LATENCY	PROCESS LATENCY	UNIT PRODUCTIVITY	PROCESS PRODUCTIVITY	UNIT PERFORMANCE	PROCESS PERFORMANCE	BACK	POSSIBLE	TRANSLATION
RCF	53100.00	39656.00	39656.00	36028.85	0.75	0.75	1.00	0.91	0.75	0.68	40000.00	39656.00	1
PPP	50976.00	49080.00	39656.00	34603.59	0.96	0.96	0.81	0.87	0.78	0.84	40000.00	39656.00	1
PM	41043.76	36664.22	36664.22	35242.67	0.89	0.89	1.00	0.96	0.89	0.86	42920.00	49080.00	1.073
WINDER	60743.38	55852.16	36664.22	39166.08	0.92	0.92	0.66	0.99	0.60	0.91	40000.00	36664.22	1
RCF	SETTINGS	FPP	SETTINGS	PM1	SETTINGS	PM2	SETTINGS	WINDER 1	SETTINGS	WINDER 2	SETTINGS	REWIND	SETTINGS
LIMIT	37.50	LIMIT	36.00	LIMIT	910.00	LIMIT	1700.00	LIMIT	1000.00	LIMIT	1200.00	LIMIT	1000.00
RATE	32.00	RATE	33.00	RATE	905.00	RATE	1650.00	WEIGHT	48.50	WEIGHT	44.60	WEIGHT	44.60
LINES	2.00	LINES	2.00	WIDTH	5.40	WIDTH	9.40	WIDTH	5.40	WIDTH	9.40	WIDTH	9.40
HOURS	20.00	HOURS	24.00	WEIGHT	48.50	WEIGHT	44.60	HOURS	20.00	HOURS	20.00	HOURS	20.00
DAYS	31.00	DAYS	31.00	LINES	1.00	LINES	1.00	TLOSS	3.50%	TLOSS	2.48%	TLOSS	0.00%
PSHUT	12.00	PSHUT	12.00	HOURS	24.00	HOURS	24.00	JR LOSS	0.90%	JR LOSS	0.90%	JR LOSS	0.00%
UPSHUT	12.00	UPSHUT	12.00	DAYS	31.00	DAYS	31.00	BEATER	3.00%	BEATER	0.52%	BEATER	0.00%
TARGET	39656.00	TARGET	49080.00	PSHUTS	2.80%	PSHUTS	2.90%	CULL	1.00%	CULL	1.00%	CULL	0.00%
				UPSHUTS	5.80%	UPSHUTS	2.90%	PSHUTS	2.80%	PSHUTS	2.90%	PSHUTS	0.00%
				BREAKS	3.00%	BREAKS	3.00%	UPSHUTS	5.80%	UPSHUTS	2.90%	UPSHUTS	0.00%
				JR LOSS	0.90%	JR LOSS	0.90%	BREAKS	3.00%	BREAKS	3.00%	BREAKS	0.00%
				BEATER	3.00%	BEATER	0.52%	LINES	1.00	LINES	2.00	LINES	1.00
				GROSS	10680.55	GROSS	30879.54	NO. OF DAYS	31.00	NO. OF DAYS	31.00	NO. OF DAYS	31.00
				NET	8940.57	NET	27723.65	GROSS	9401.69	GROSS	36501.49	GROSS	15695.73
				UNIT MAX	10275.65	UNIT MAX	30768.11	NET	7850.41	NET	32406.02	NET	15695.73
				COMBINED TARGET		13 & 14	36664.22	UNIT MAX	9428.40	UNIT MAX	36222.34	UNIT MAX	15092.64
								COMBINED TARGET		13 & 14	55852.16		

Fig 10.1 Fusion21 Value Generating Activities

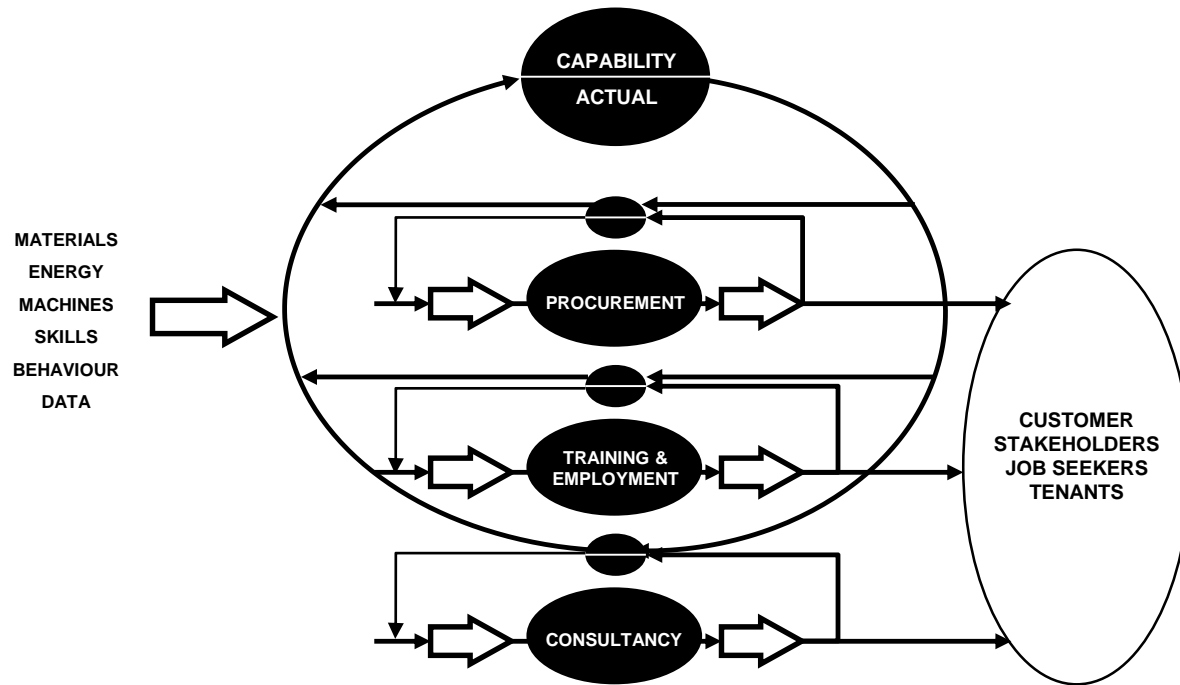

Fig 10.2 Fusion21 Value Enabling Activities

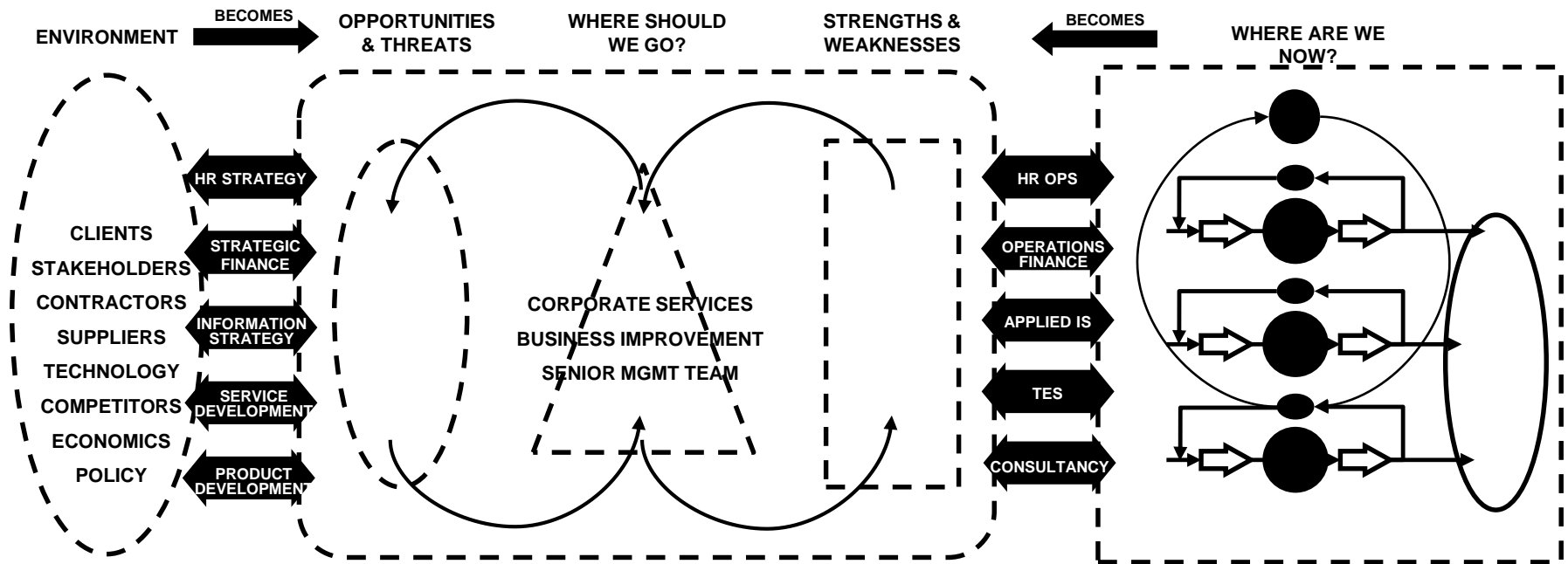

Fig 10.3 Fusion21 Data Flow Diagram

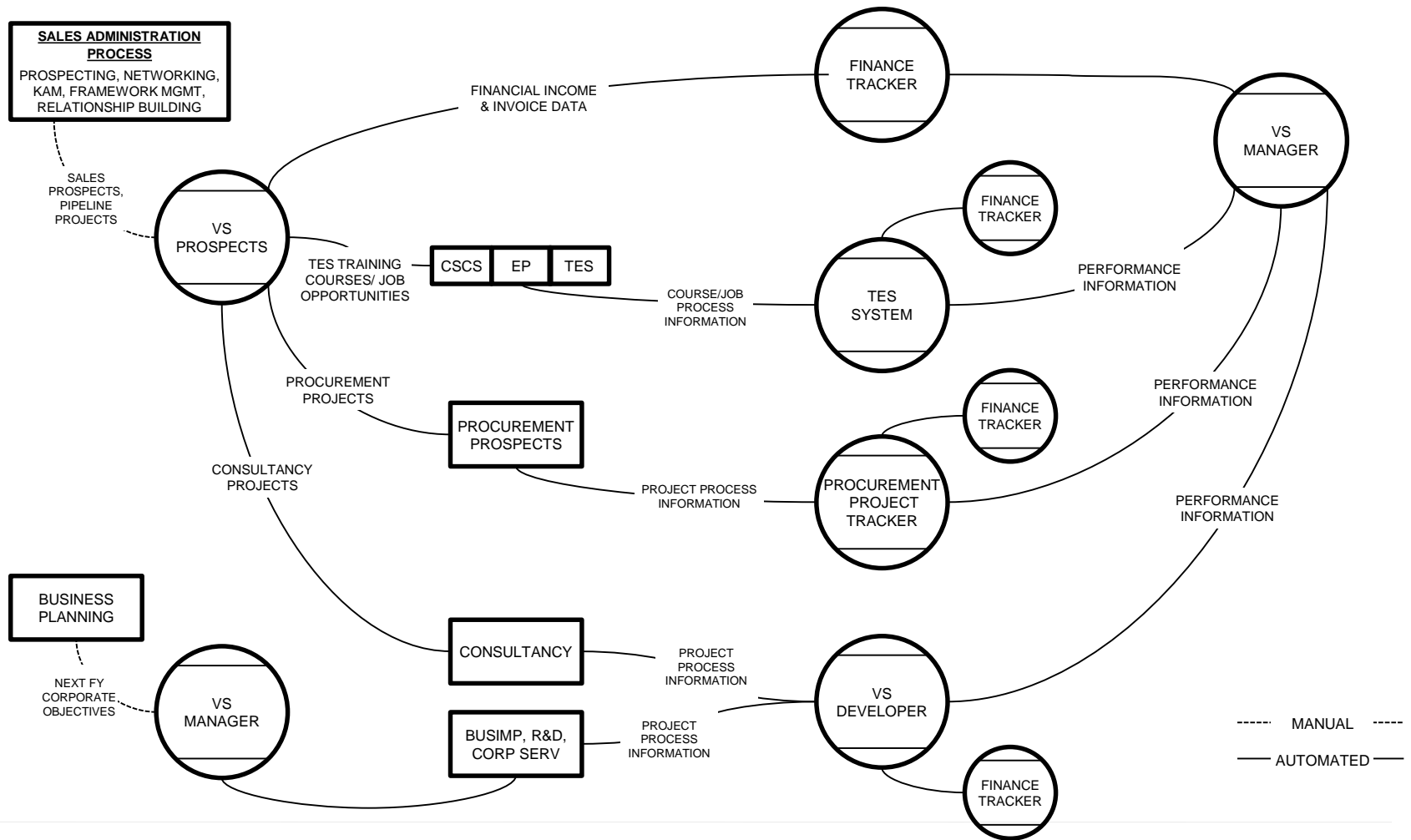
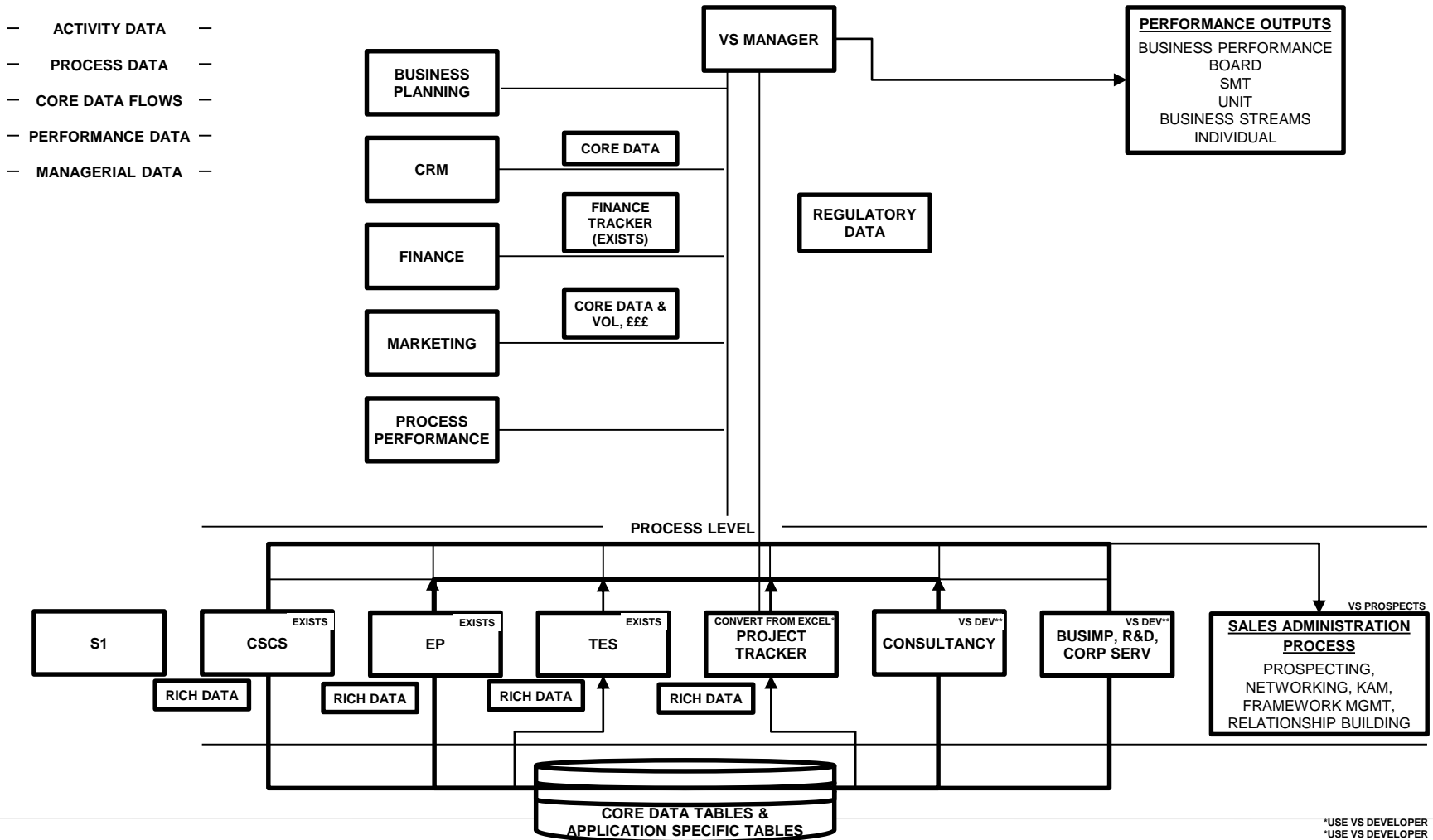
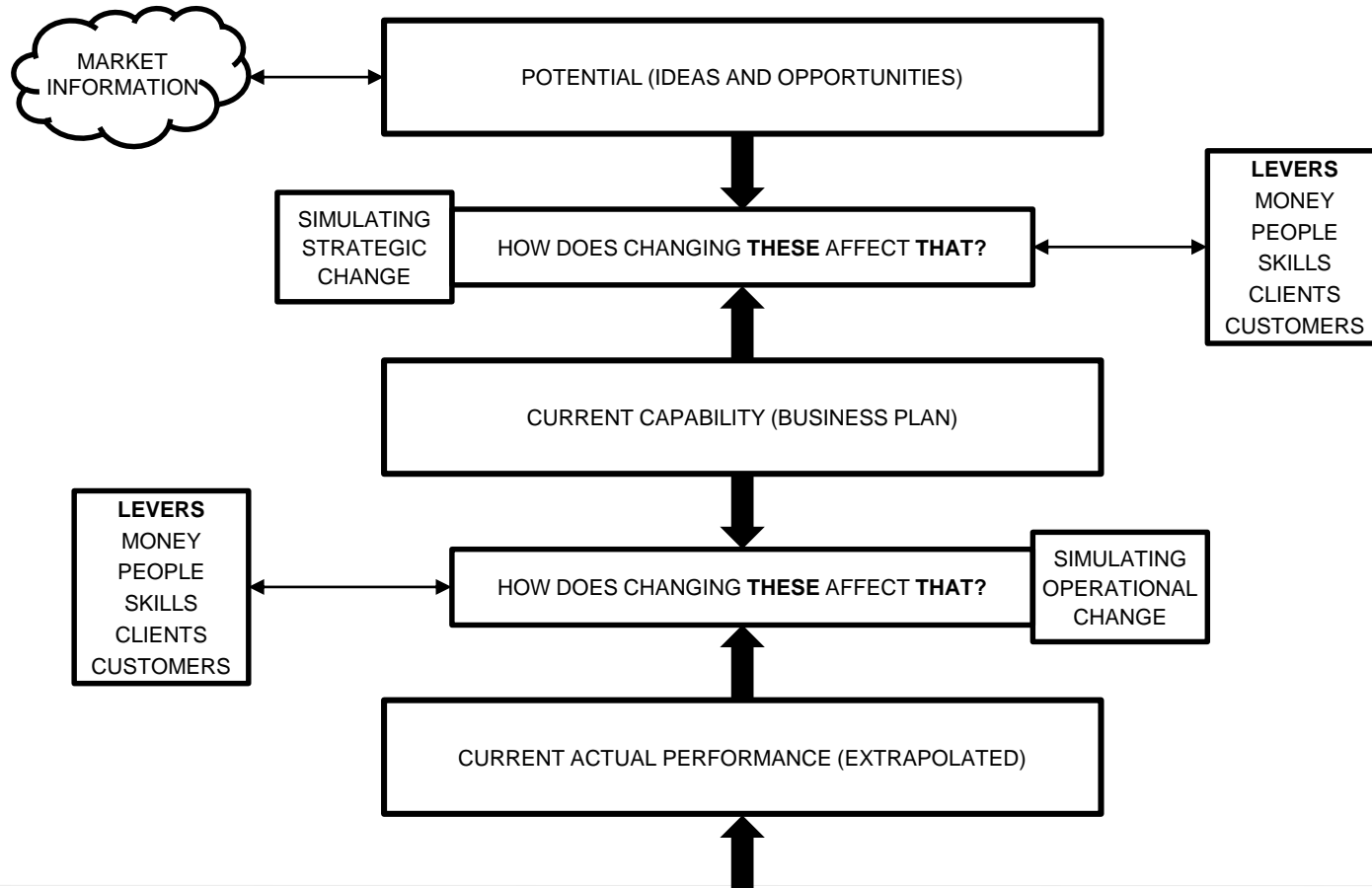
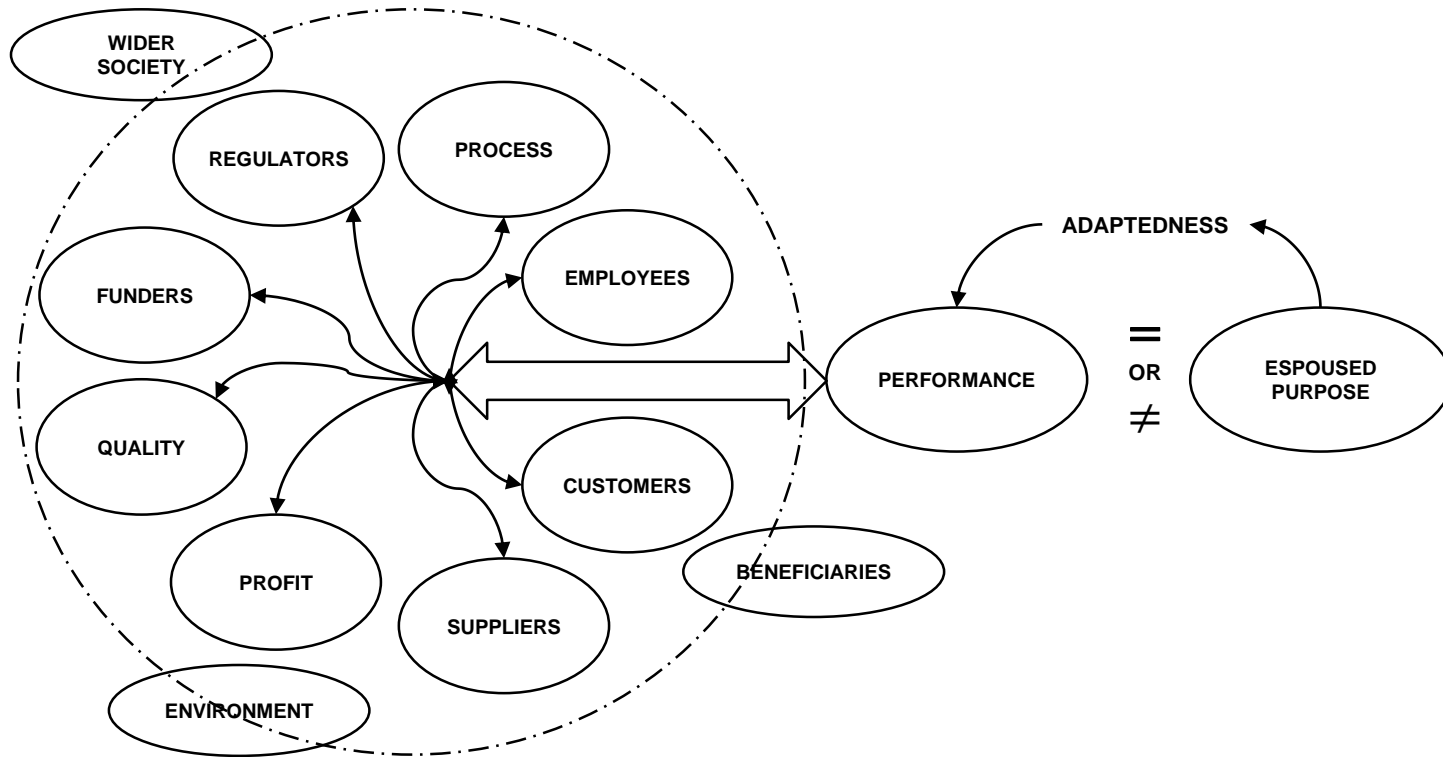

Fig 10.4 Fusion21 Information Architecture



*USE VS DEVELOPER
 **USE VS DEVELOPER





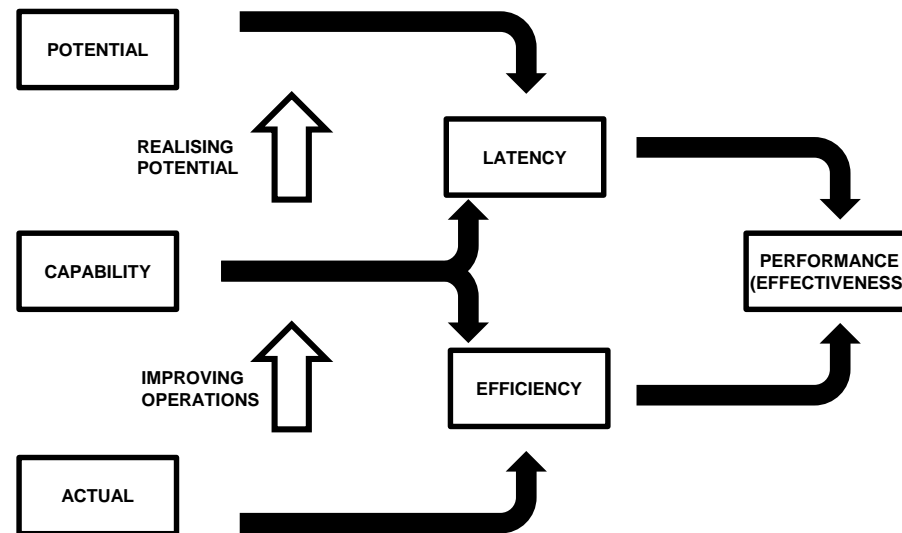

Fig 11.3 Synthesising Potentiometers

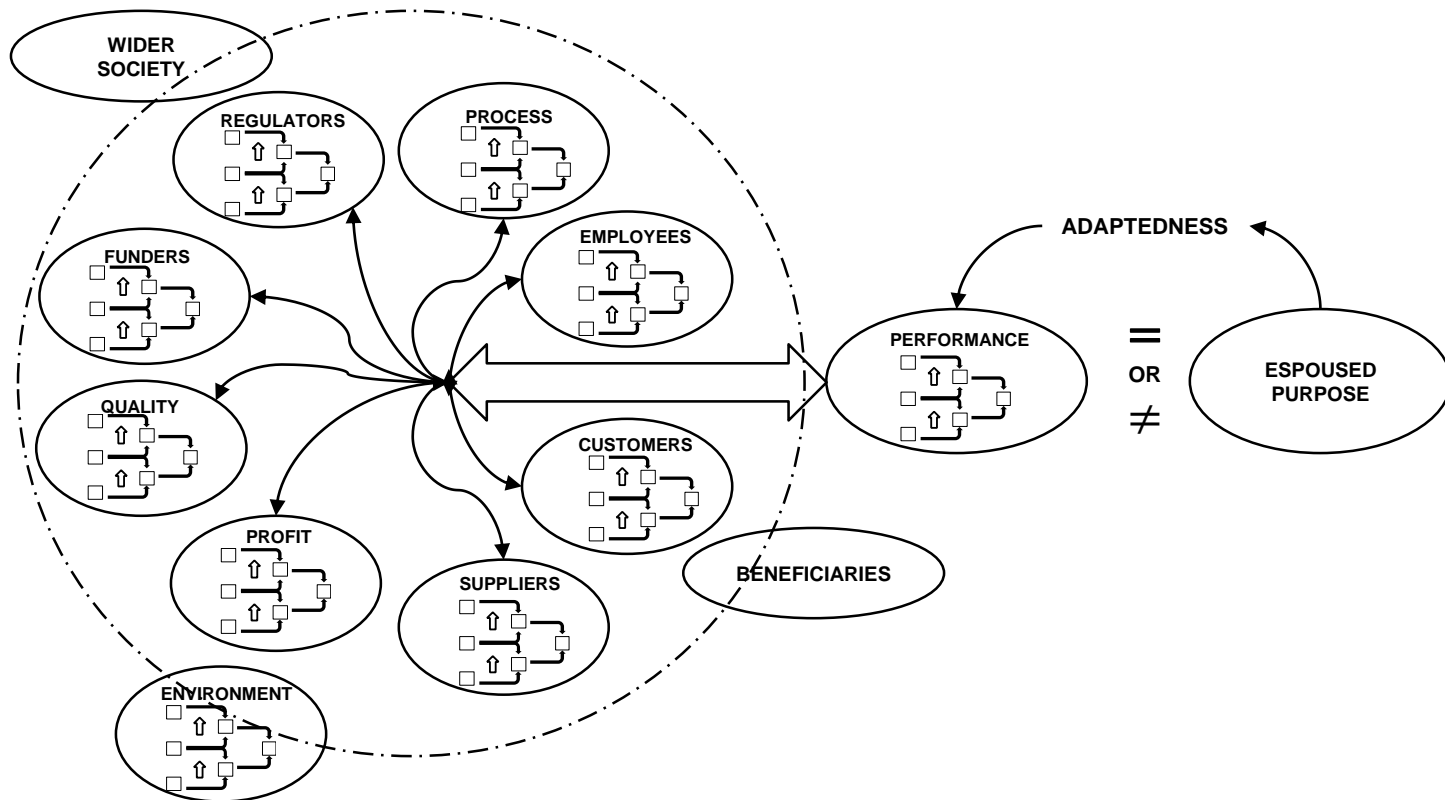

Fig 12.1 Train Company Interacting Processes

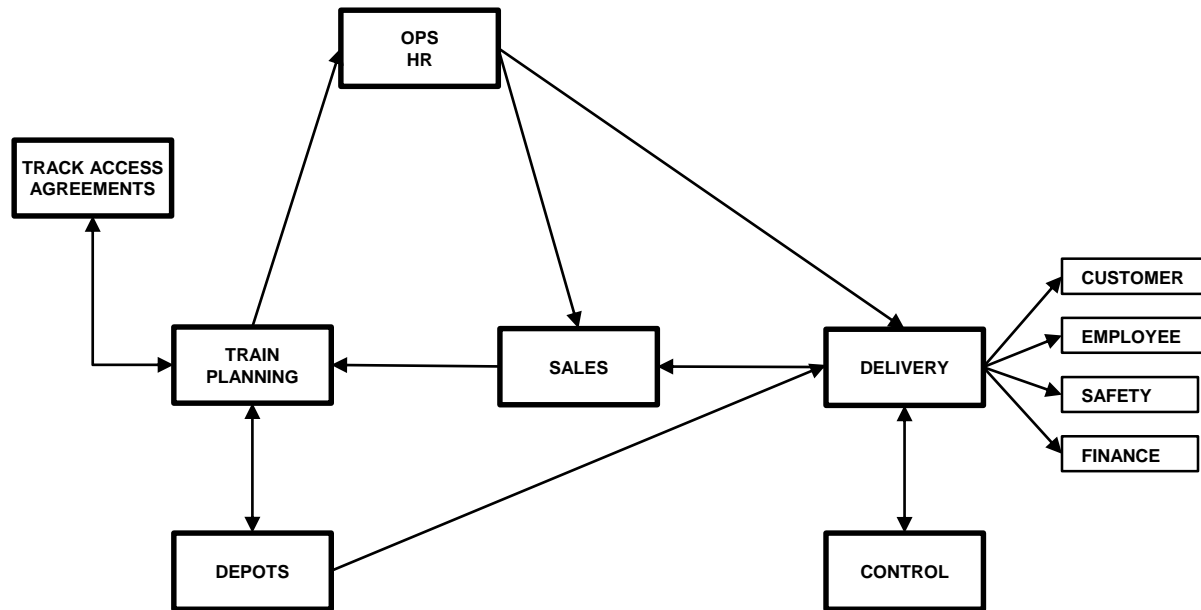
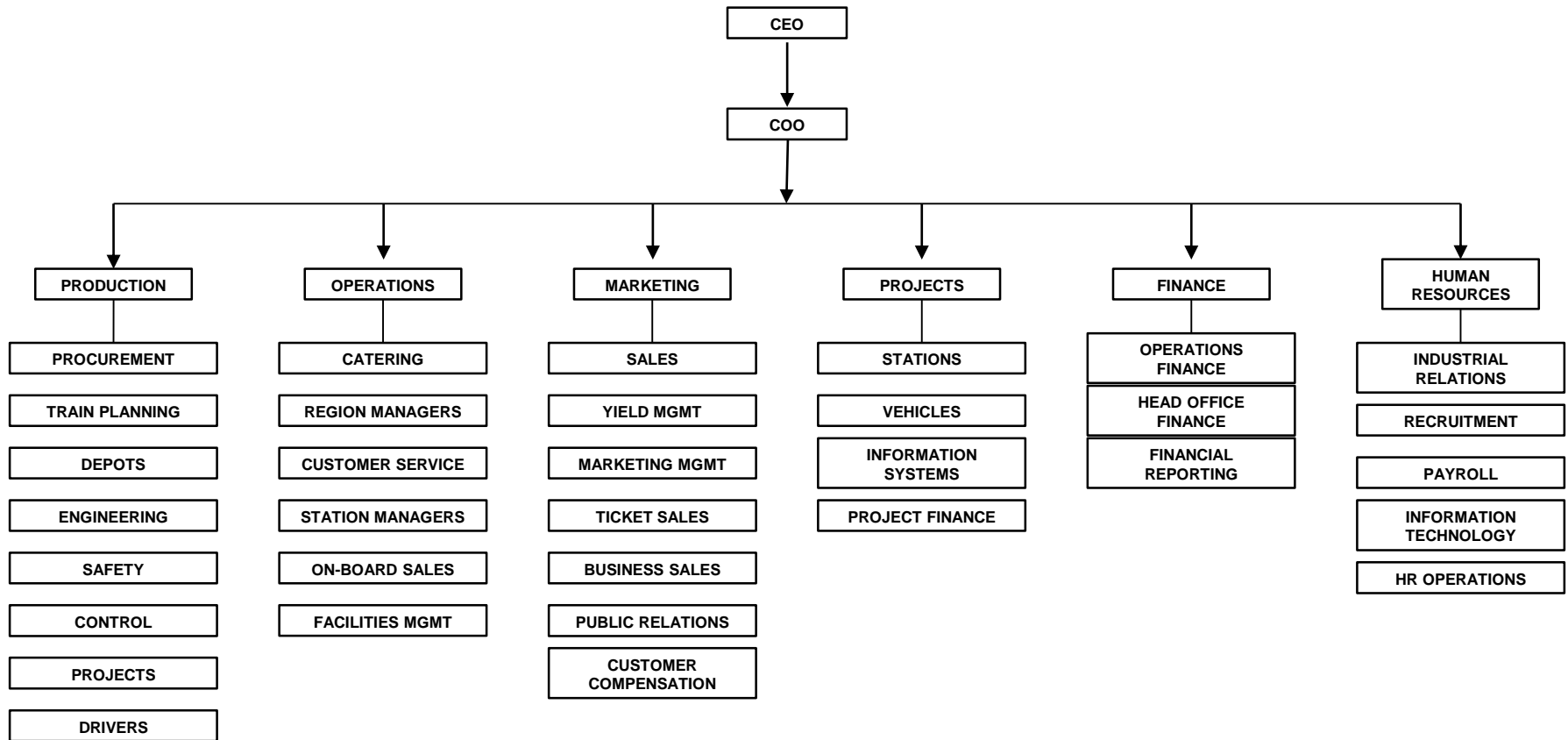
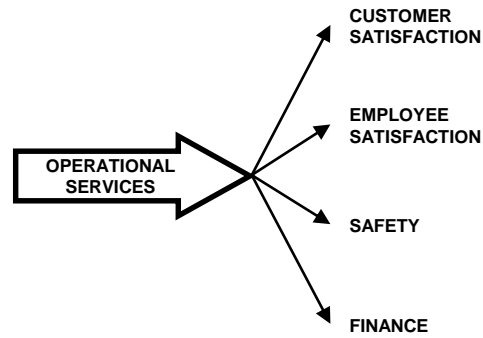
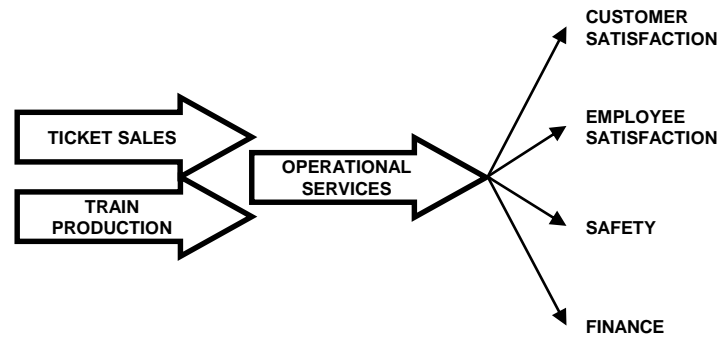
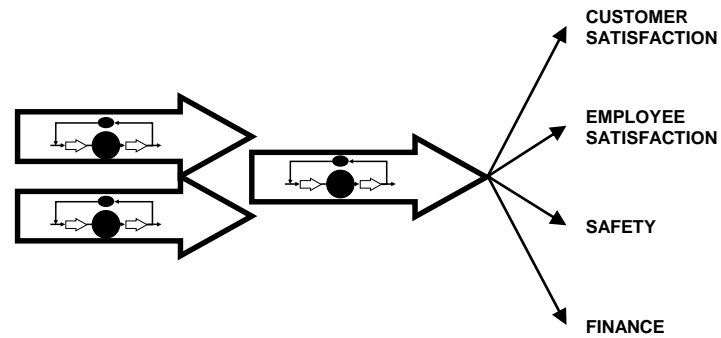

Fig 12.2 Train Operating Company Hierarchy









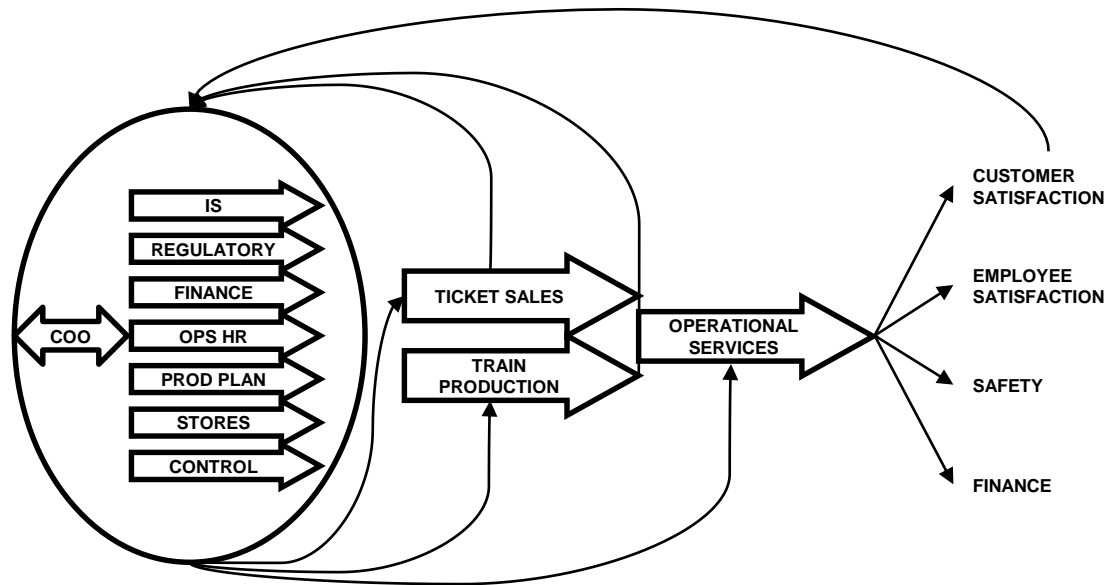

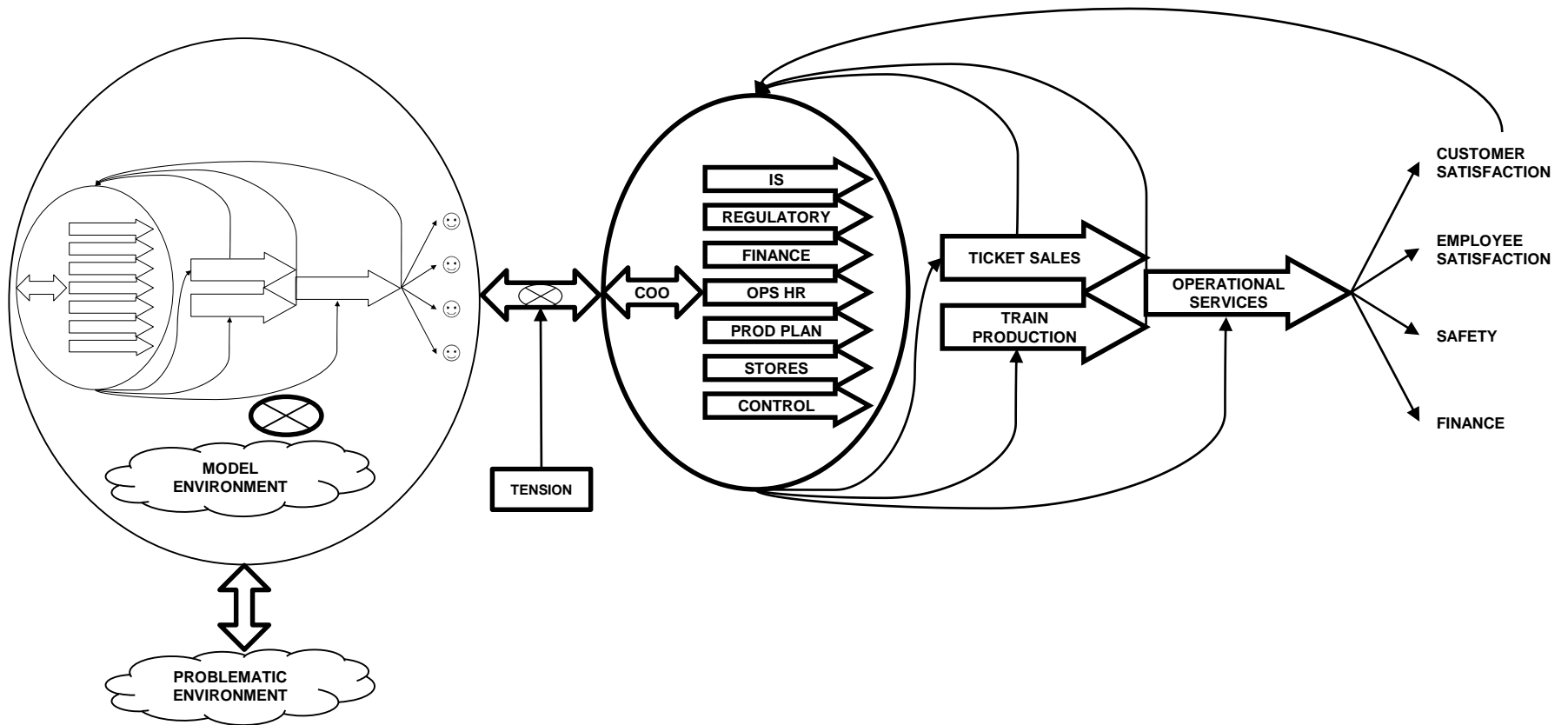

Fig 12.8 Resolving Tension

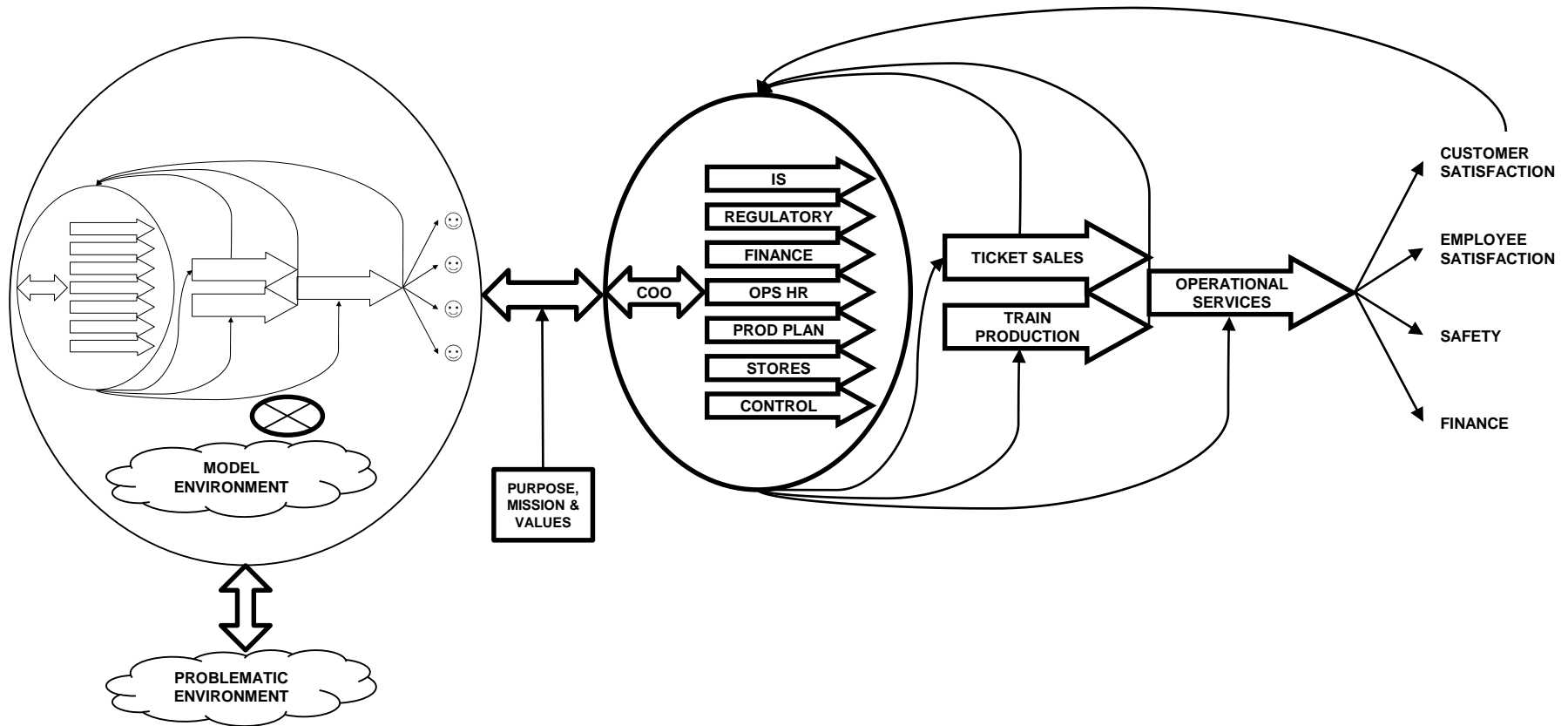
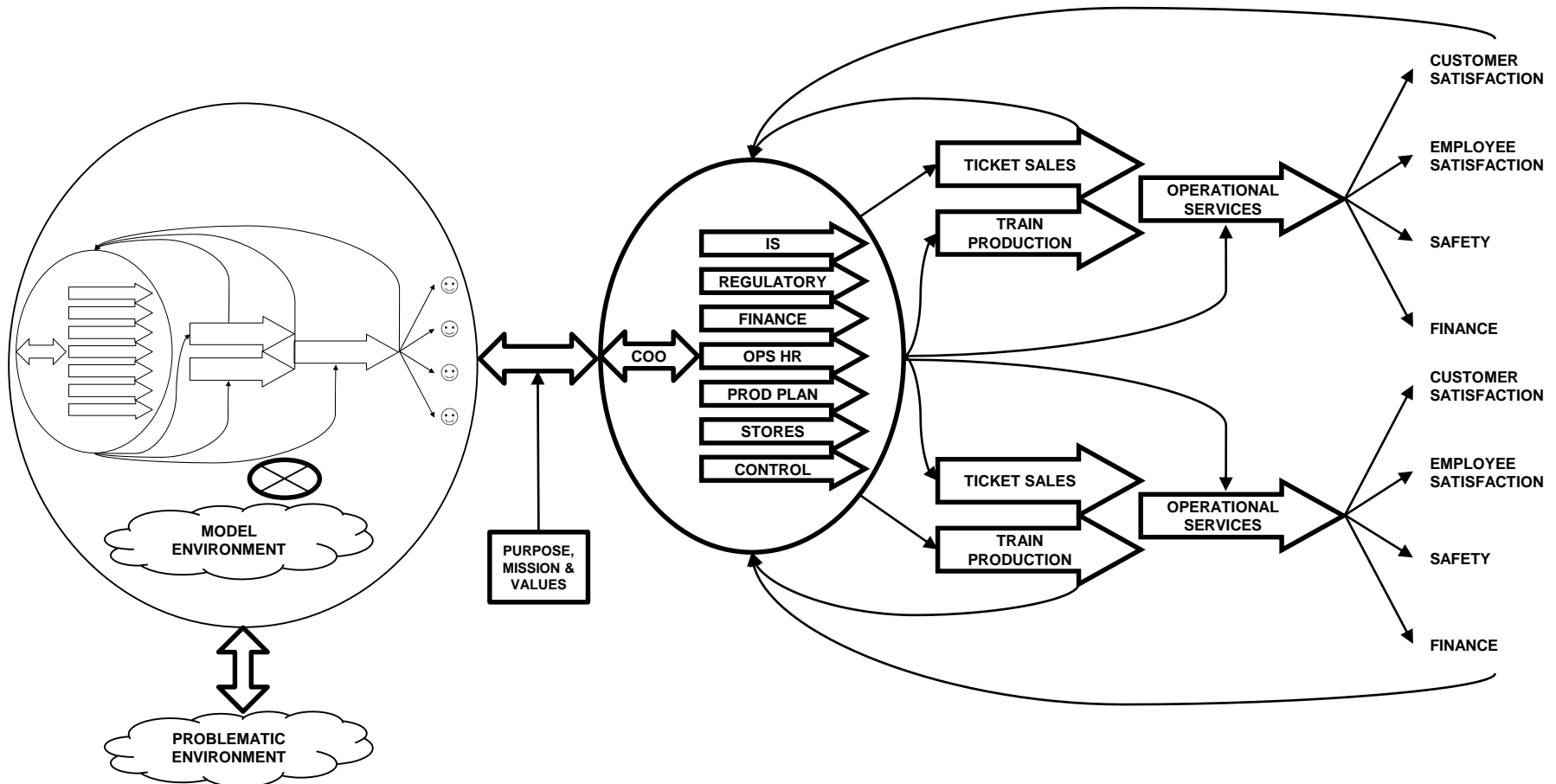
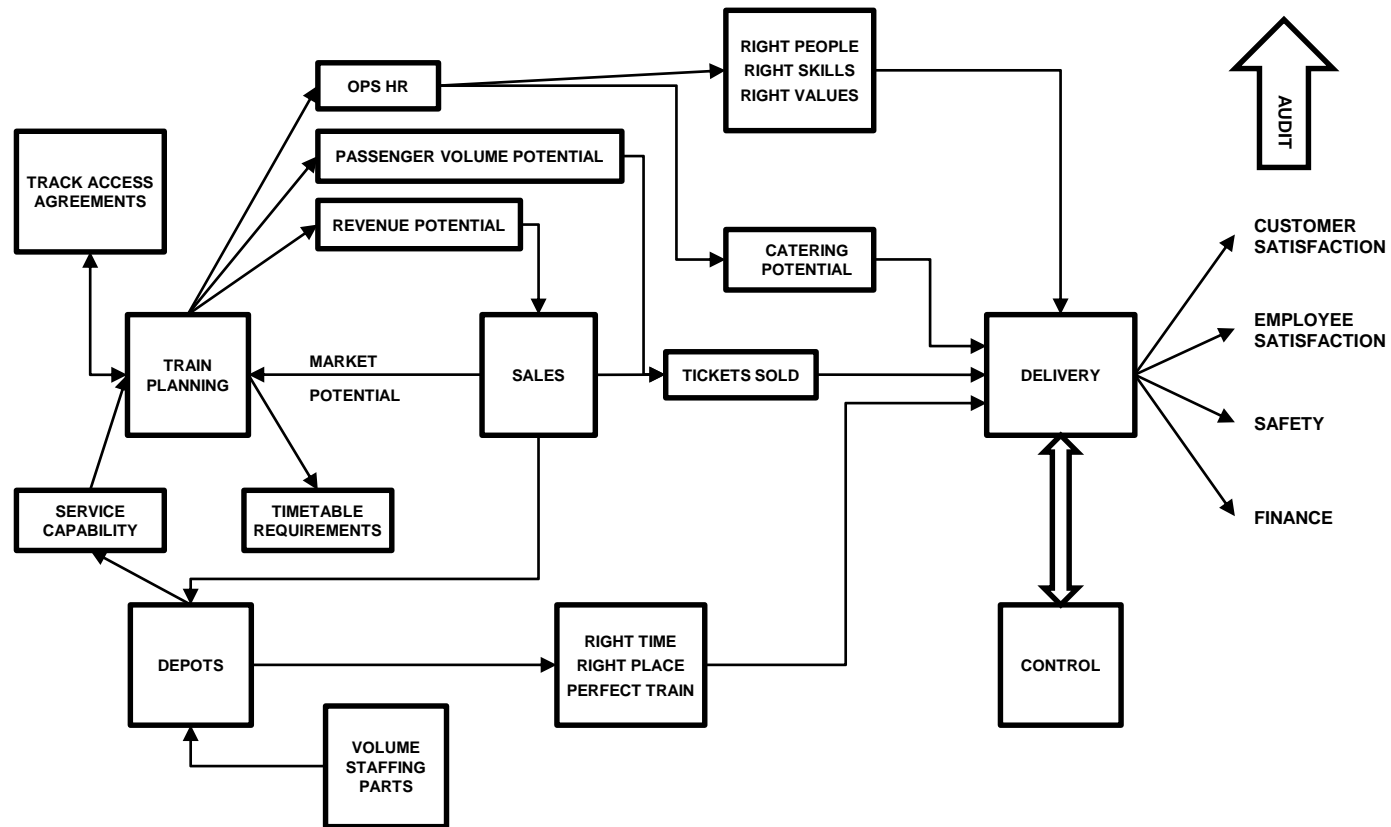

Fig 12.9 Integrated Businesses





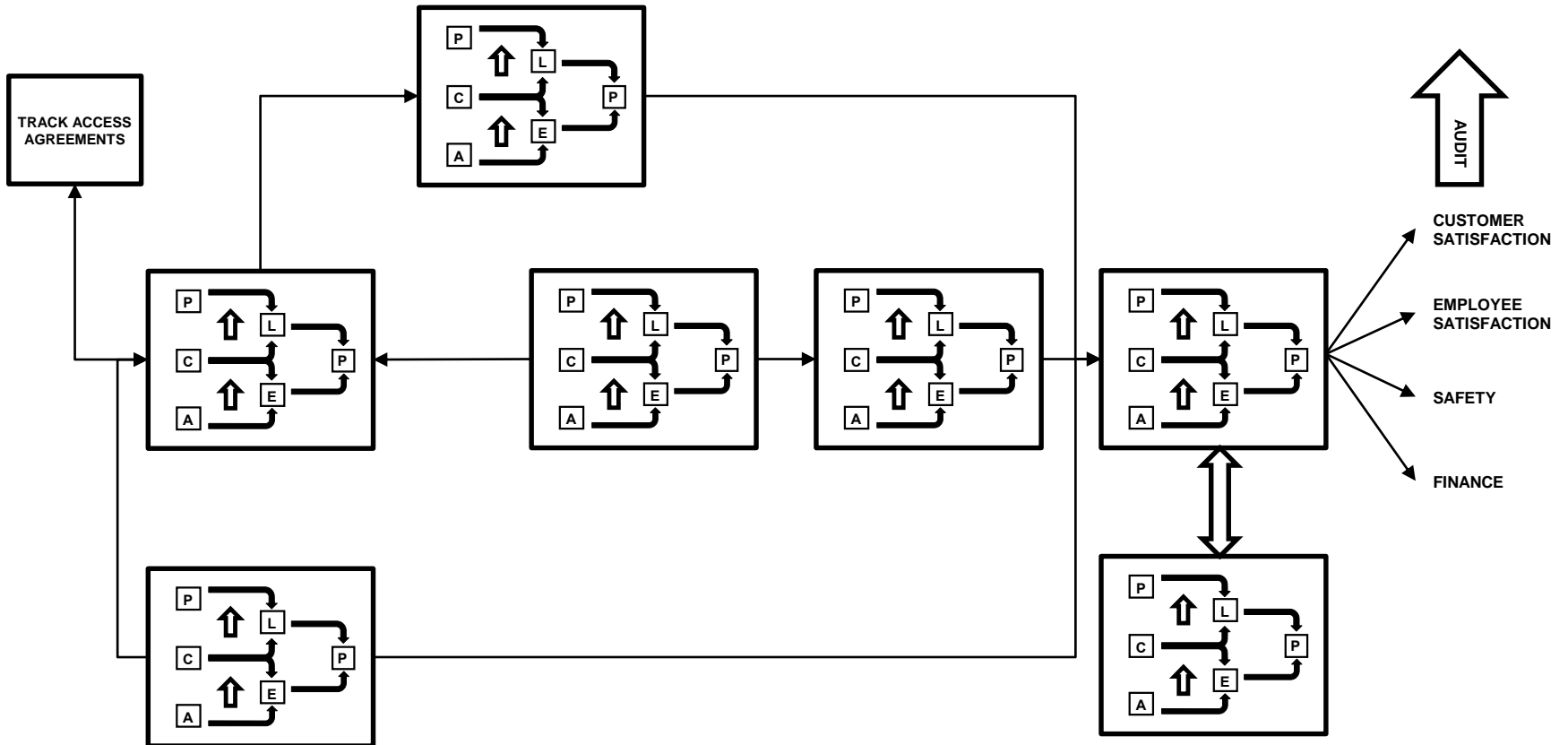

Fig 12.12 Measuring Performance

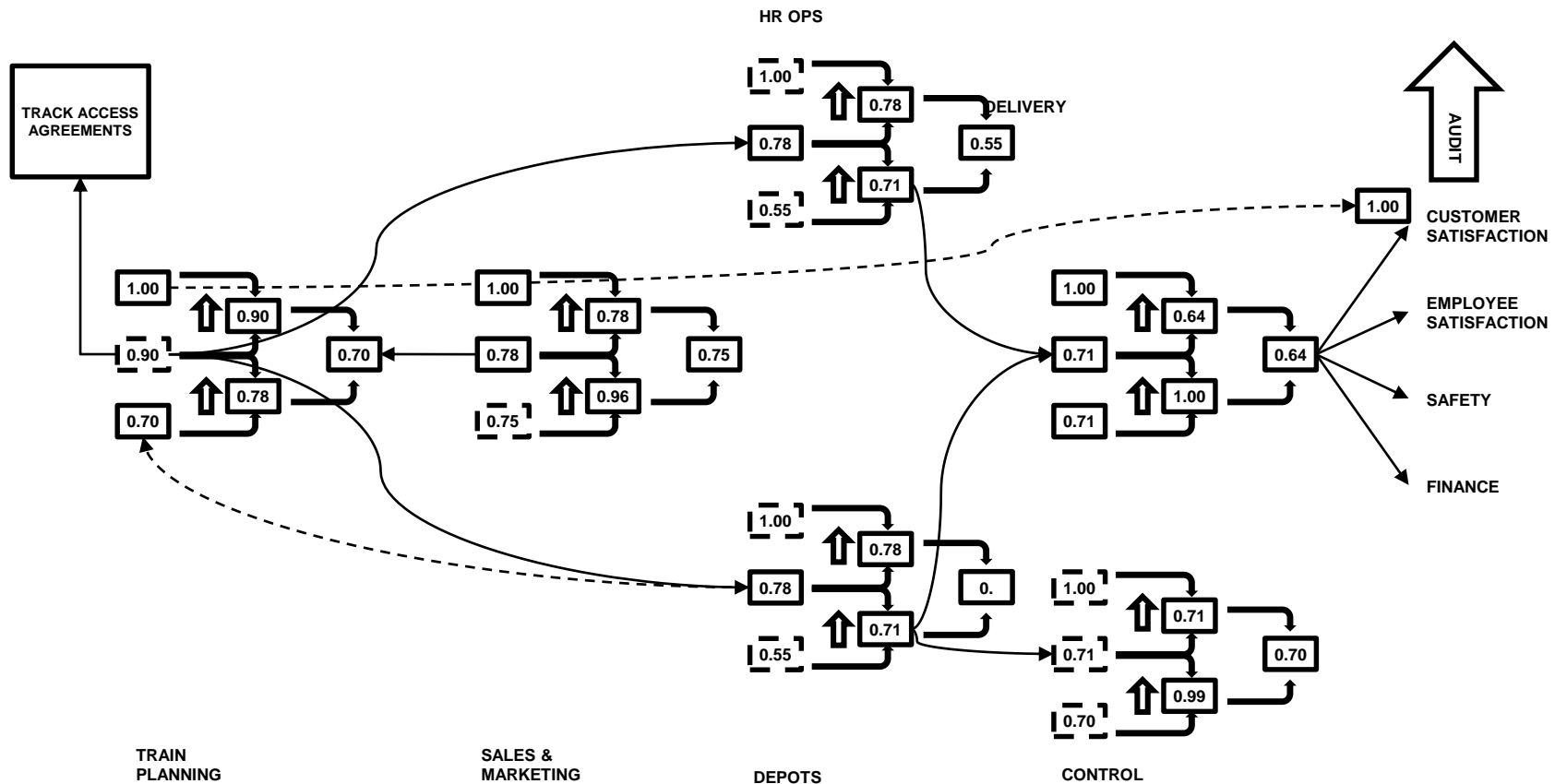

Fig 13.1 Dimensions of Economy and Freedom

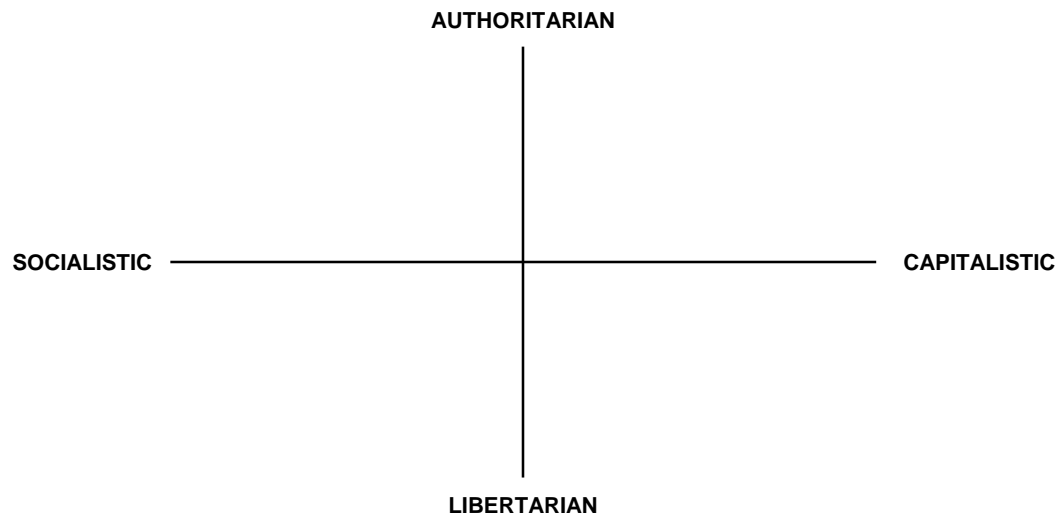
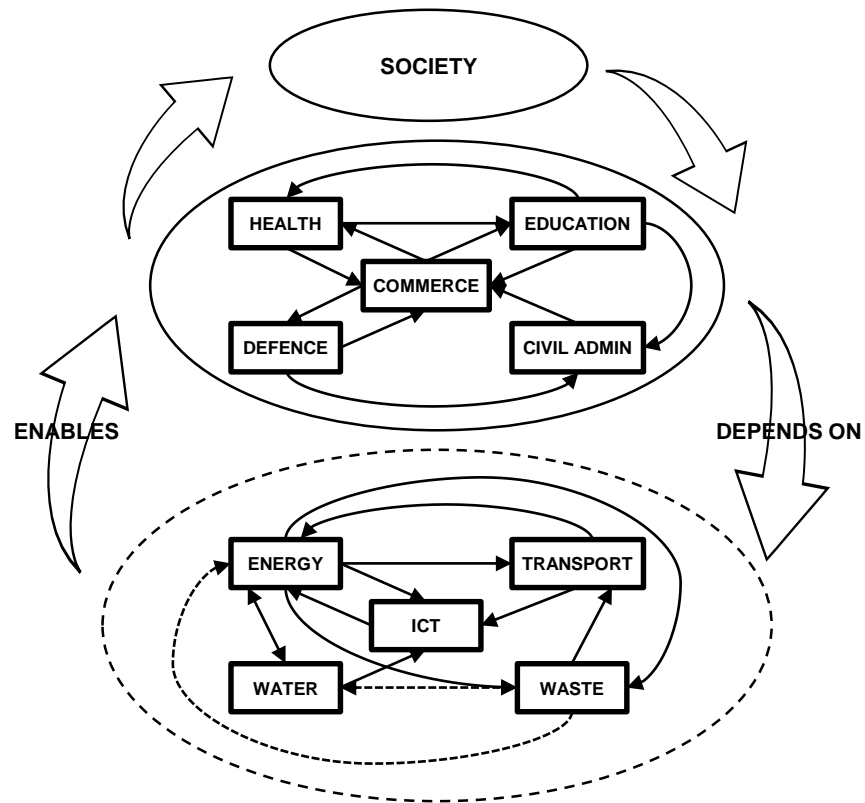
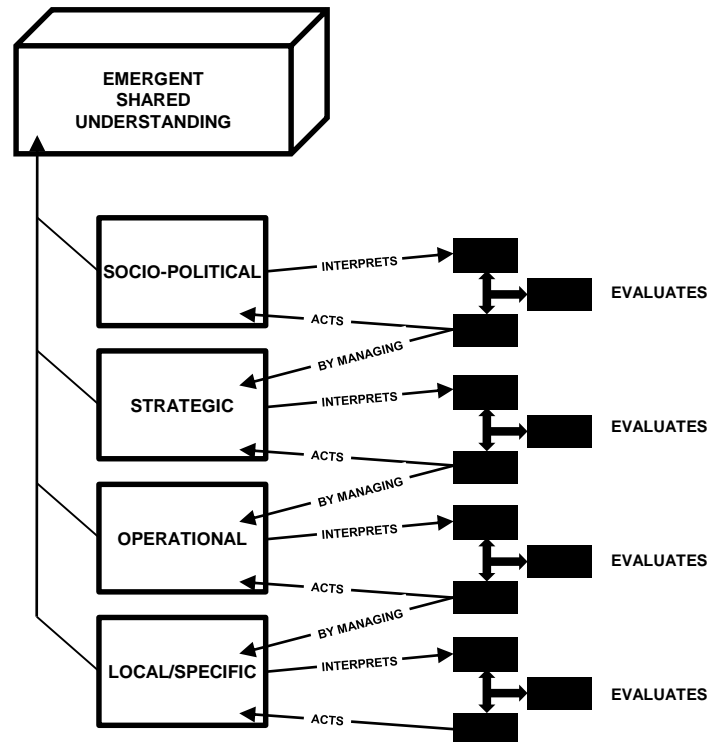

Fig 14.1 National Interdependencies





INFRASTRUCTURE AVAILABILITY + SERVICE AVAILABILITY = JOURNEY AVAILABILITY (PROXY = DELAY MINUTES)

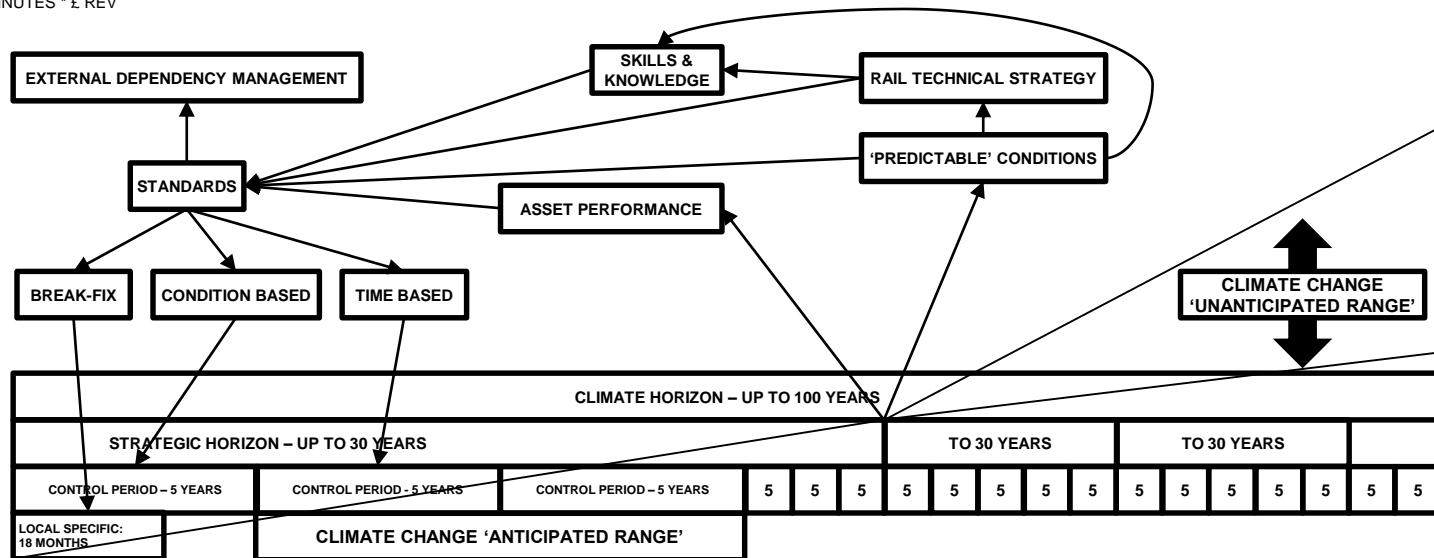
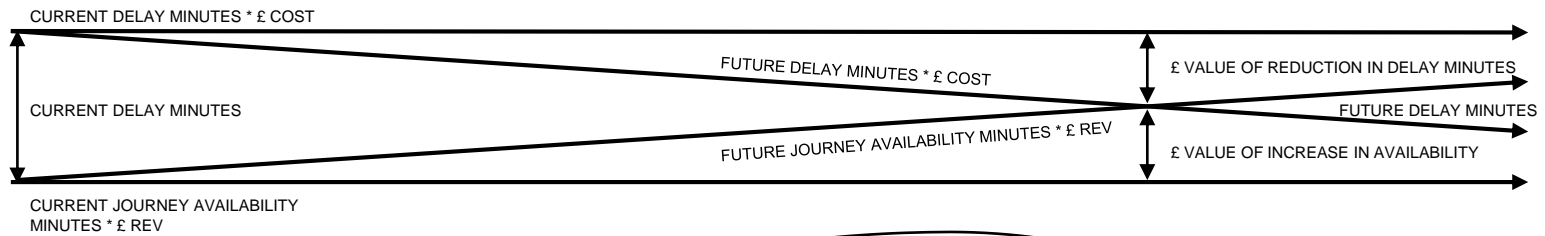
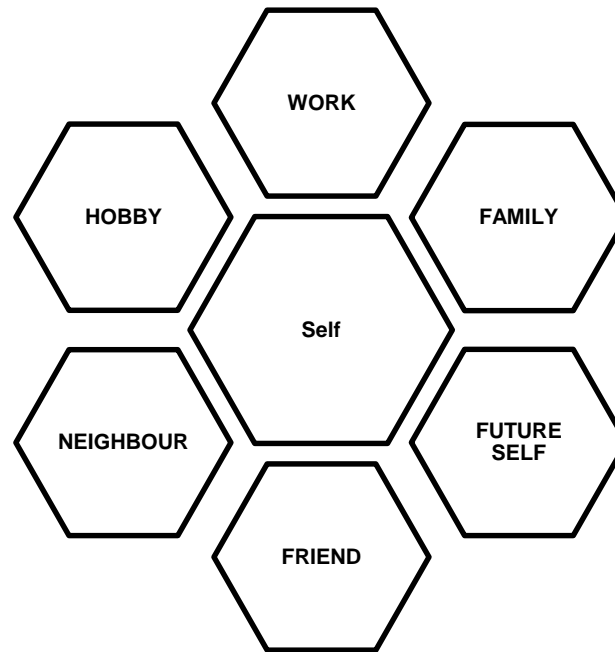
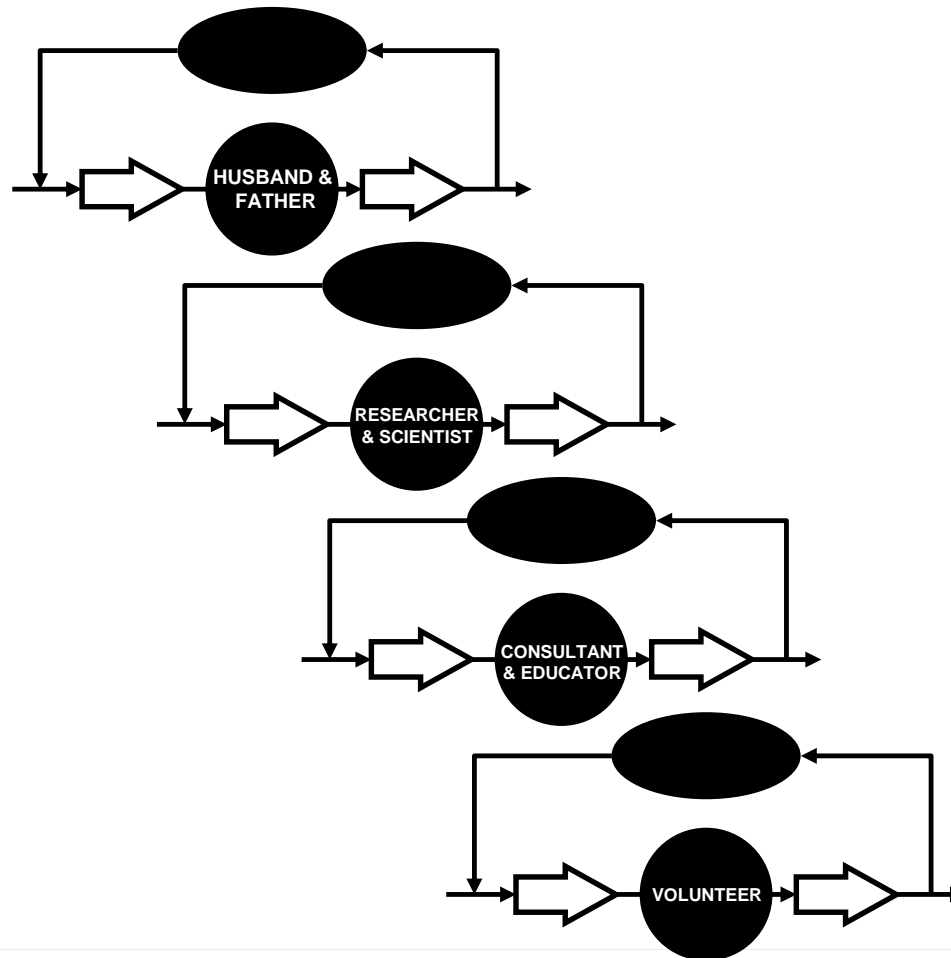

Fig 15.1 Self at the Centre of the Network





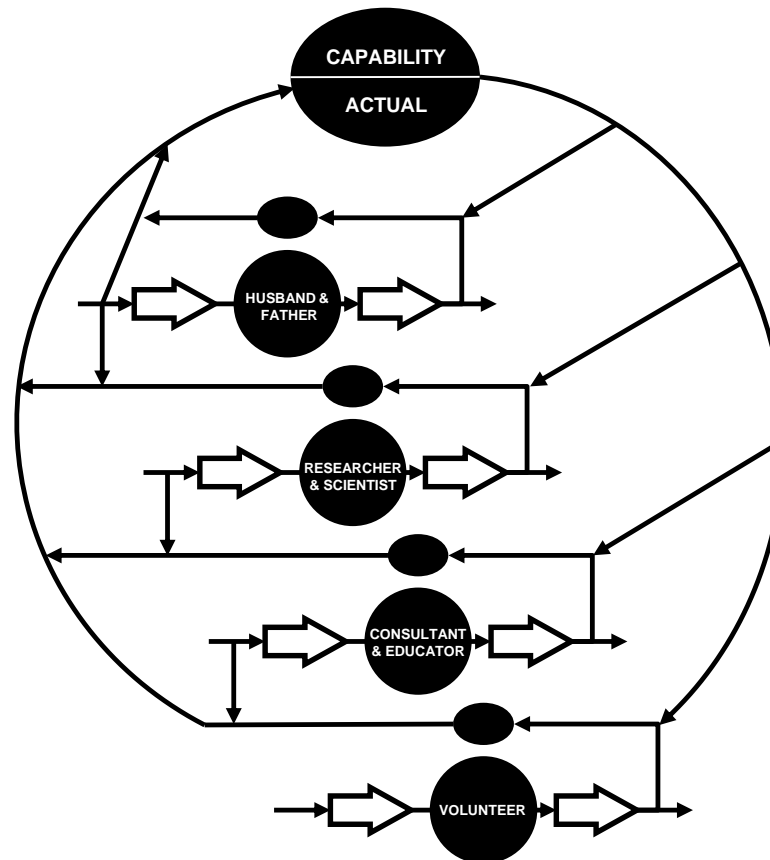
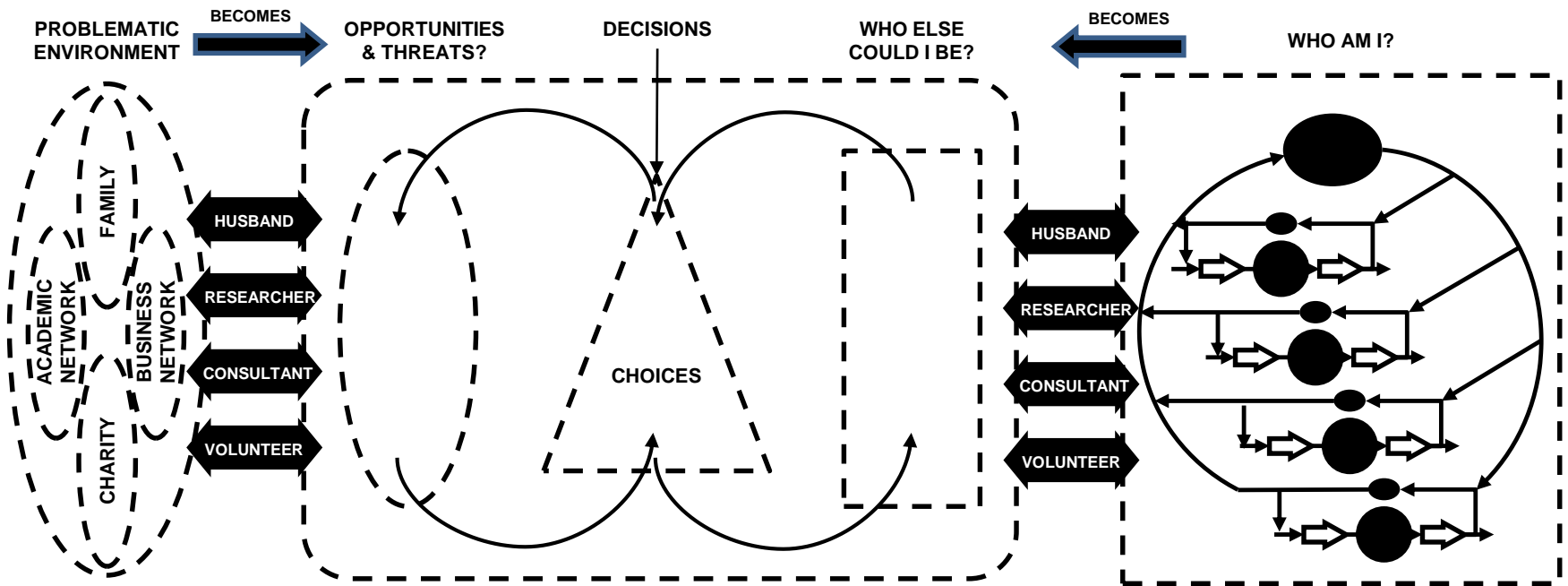

Fig 15.4 Enabling Value for the Individual



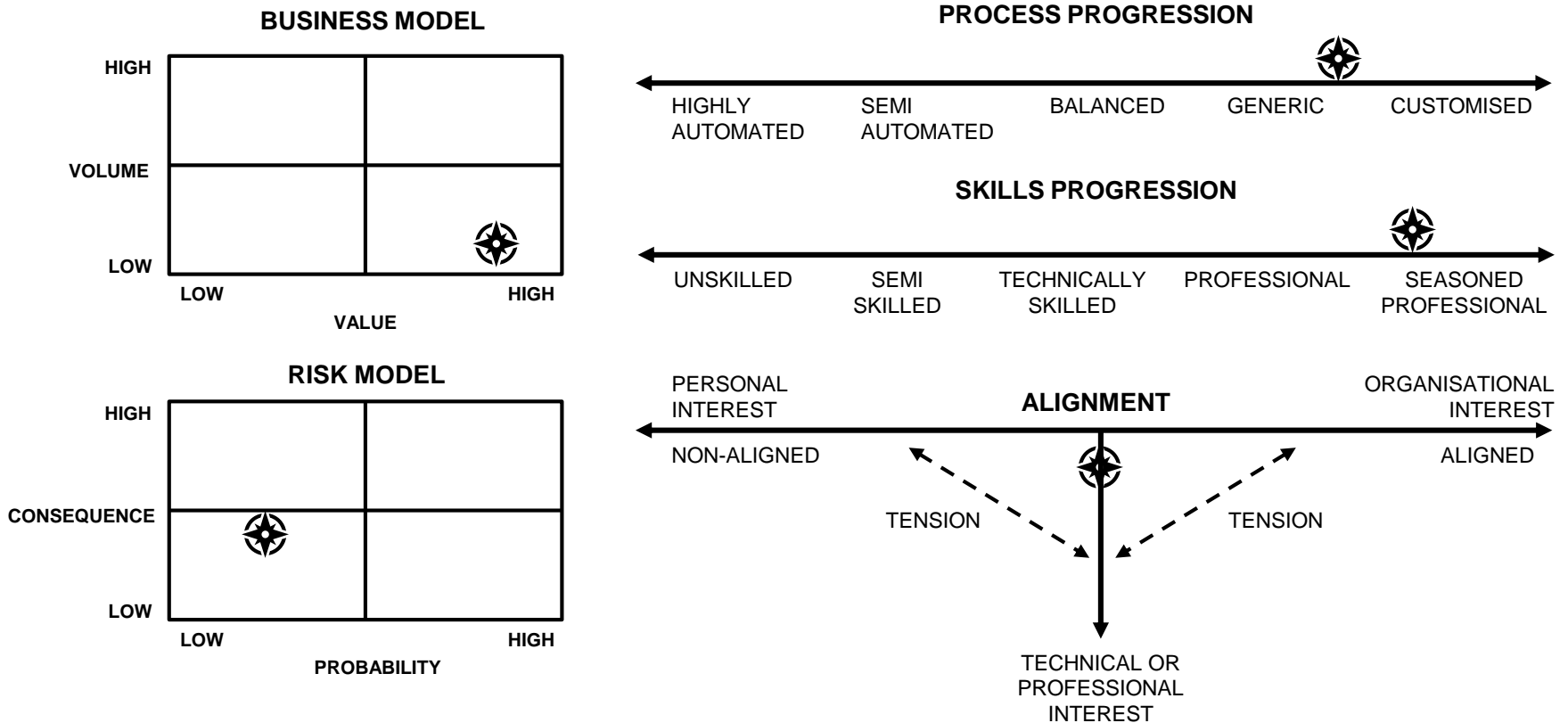

Fig 16.1 Developing a Shared Model

